

CONVEY-ALL[®]

OPERATOR'S MANUAL



BIN FILL CONVEYOR with MECHANICAL BELT DRIVE

1665 • 1675 • 1685

**PRODUCT REGISTRATION FORM
and INSPECTION REPORT**

CONVEY-ALL®

The Dealer must fill out this form, and be signed by both the Dealer and Buyer at the time of delivery. Scan or photograph the completed form (must be legible), and email it to: register@convey-all.com A copy of this form may also be mailed to: Box 760, 275 Hespler Ave, Winkler Manitoba R6W 4A8.

Buyer's Name _____	Dealer's Name _____
Address _____	Address _____
City _____	City _____
Province/State _____	Province/State _____
Postal/Zip Code _____	Postal/Zip Code _____
Country _____	Country _____
Phone Number _____	Phone Number _____
Model Number _____	Serial Number _____
Delivery Date _____	General Purpose: <input type="checkbox"/> Private <input type="checkbox"/> Commercial

UNIT INSPECTION

- All Fasteners Tight
- Engine/Hydraulic Fluid Levels Checked
- Drive Belts Aligned and Tensioned
- Drive System Rotates Freely
- Hydraulic Hoses Good, Fittings Tight
- Machine and All Bearings Lubricated
- Conveyor Belt Aligned and Tensioned
- Conveyor Belt Moves Freely
- Conveyor Tube Raises and Lowers Smoothly
- Unit Steers and Drives Smoothly
- Tire Pressure Checked

SAFETY INSPECTION

- All Guards/Shields Installed and Secured
- All Safety Decals Clear and Legible
- Reflectors, Slow Moving Vehicle Sign are Clean
- All Lights are Clean and Working
- Safety Chain on Hitch
- Reviewed Operating and Safety Instructions

I have thoroughly instructed the buyer on the above described equipment. The review included the content of the Operator's Manual, equipment care, adjustments, safe operation and warranty policy.

Date _____ Dealer's Signature _____

The above equipment and Operator's Manual have been received by me. I have been thoroughly instructed as to care, adjustments, safe operation and applicable warranty policy.

Date _____ Buyer's Signature _____

This page intentionally left blank

TABLE OF CONTENTS

DESCRIPTION	PAGE
Section 1: INTRODUCTION	1-1
1.1 Operator Orientation	1-1
1.2 Serial Number	1-1
Section 2: SAFETY.	2-1
2.1 Safety Orientation	2-2
2.2 General Safety	2-2
2.3 Equipment Safety Guidelines.	2-3
2.4 Safety Decals.	2-3
2.5.1 Applying Decals.	2-3
2.5 Decal Location.	2-4
2.6 Work Preparation	2-5
2.7 Placement Safety.	2-5
2.8 Lock-Out Tag-Out Safety.	2-5
2.9 Maintenance Safety	2-6
2.10 Tire Safety	2-6
2.11 Battery Safety	2-6
2.12 Engine Safety.	2-7
2.13 Operating Safety	2-8
2.14 Hydraulic Safety.	2-8
2.15 Workplace Hazard Area	2-9
2.16 Transport Safety.	2-10
2.17 Storage Safety	2-10
Section 3: OPERATION	3-1
3.1 Machine Components	3-2
3.2 Components and Controls.	3-3
3.3 Machine Break-In.	3-9
3.4 Pre-Operation Checklist.	3-9
3.5 Attaching to Tow Vehicle	3-10
3.6 Conveyor Placement	3-12
3.7 Operating on Site.	3-14
3.7.1 Starting Conveyor	3-14
3.7.2 Stopping Conveyor	3-15
3.7.3 Emergency Stopping	3-15
3.7.4 Restarting after Emergency Stop.	3-15
3.7.5 Unplugging.	3-15

continue on next page

TABLE OF CONTENTS

DESCRIPTION	PAGE
3.8 Operating Hints	3-16
3.9 Transportation	3-17
3.10 Storage.....	3-19
Section 4: SERVICE AND MAINTENANCE	4-1
4.1 Fluids and Lubricants.....	4-1
4.1.1 Greasing.....	4-2
4.2 Servicing Intervals	4-3
4.2.1 Every 10 Hours or Daily	4-3
4.2.2 Every 50 Hours or Weekly	4-4
4.2.3 Every 100 Hours or Monthly	4-5
4.2.4 Every 200 Hours or Annually	4-6
4.3 Maintenance Procedures.....	4-8
4.3.1 Conveyor Belt Tension.....	4-8
4.3.2 Conveyor Belt Alignment	4-9
4.3.3 Conveyor Belt Replacement	4-11
4.3.4 Drive Belt Tension	4-12
4.3.5 Check Pulley Alignment.....	4-13
4.3.6 Drive Belt Replacement.....	4-13
4.3.7 Change Hydraulic Oil.....	4-14
4.3.8 Change Hydraulic Oil Filter	4-14
4.3.9 Hopper Flushing Replacement.....	4-15
4.3.10 Drive Wheel Gear Adjustment	4-16
4.3.11 Hydraulic Drive Motor Replacement	4-17
4.4 Service Record.....	4-19
4.5 Ordering Parts	4-20
Section 5: TROUBLESHOOTING.....	5-1
Section 6: REFERENCE.....	6-1
6.1 Bolt Torque.....	6-3
Warranty Statement	

Section 1: INTRODUCTION

Thank you for choosing a Convey-All® Bin Fill Conveyor.

Convey-All® products are built by Meridian Manufacturing Inc. The equipment we design and manufacture meet the exacting standards of the agriculture industry.

Keep this manual for future reference. Call your dealer, distributor, or our office, if you need assistance, information, additional/replacement copies, or a digital version of this document.

Information provided herein is of a descriptive nature. Meridian Manufacturing Inc. reserves the right to modify the machinery design and specifications without any preliminary notice.

Performance quality may depend on the material being handled, weather conditions and other factors.

1.1 OPERATOR ORIENTATION

The directions; left, right, front and rear, as mentioned throughout this manual, are as seen from the tow vehicle driver's seat, facing the direction of travel. The hopper is the front of the conveyor.

1.2 SERIAL NUMBER LOCATION

Always give your dealer the serial number when ordering parts, requesting service or asking for other information. The conveyor's serial number is located on the tube, above the hopper.

Use the space provided for easy reference:

Conveyor Model No: _____

Conveyor Serial No: _____

Engine Model No: _____

Engine Serial No: _____

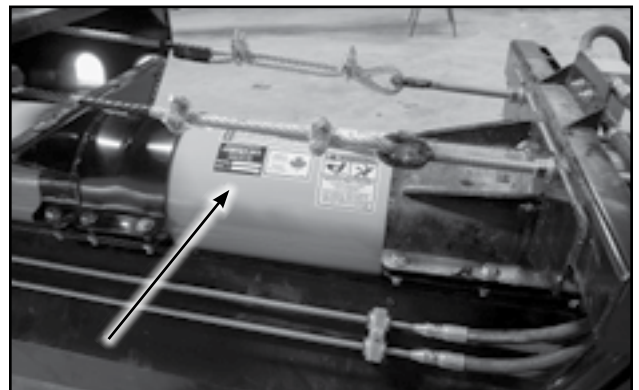

Fig 1 - Serial number location

This page intentionally left blank

Section 2: SAFETY

3 Big Reasons why safety is important to you:

- Accidents Disable and Kill
- Accidents Cost
- Accidents Can Be Avoided

The Safety Alert Symbol means:



ATTENTION!
BECOME ALERT!
YOUR SAFETY IS INVOLVED!

The Safety Alert Symbol identifies important safety messages on the conveyor and in this manual.

The following signal words are used in this manual to express the degree of hazard for areas of personal safety.

When you see the symbol and/or the signal words described below, obey the accompanying message to avoid possible injury or death.

 **DANGER**

Indicates a hazardous situation that, if not avoided, will result in death or serious injury. This signal word is limited to the most extreme situations. Typically for machine components which, for functional purposes, cannot be guarded.

 **WARNING**

Indicates a hazardous situation, if not avoided, could result in death or serious injury. This word identifies hazards that are exposed when guards are removed. It may be used to alert against unsafe practices.

 **CAUTION**

Indicates a hazardous situation, if not avoided, could result in minor or moderate injury. It may be used to alert against unsafe practices.

NOTICE

Indicates practices or situations which may result in the malfunction of, or damage to equipment.

SAFETY INSTRUCTIONS

Safety instructions (or equivalent) signs indicate specific safety-related instructions or procedures.

2.1 SAFETY ORIENTATION

YOU are responsible for the SAFE operation and maintenance of your Convey-All® Bin Fill Conveyor. Be sure that everyone who will operate, maintain or work around it, is familiar with the safety, operating and maintenance procedures.

This manual will take you step-by-step through your working day. It will alert you to all the safe practices that should be adhered to while operating the conveyor.

Remember, you are the key to safety. Good safety practices not only protect you but also the people around you. Make these practices a regular part of your safety program. Be certain that everyone who will work with this equipment follows these procedures.

Most accidents can be prevented. Do not risk injury or death by ignoring good safety practices.

- Conveyor owners must give operating instructions to operators or employees before allowing them to operate the machine.

Procedures must be reviewed annually thereafter, as per OSHA (Occupational Safety and Health Administration) regulation 1928.57.

- The most important safety device on this equipment is a SAFE operator. It is the operator's responsibility to understand all safety and operating instructions in this document, and to follow them.
- An untrained operator exposes himself and bystanders to possible serious injury or death.
- Think SAFETY! Work SAFELY!

2.2 GENERAL SAFETY

- Read and understand the Operator's Manual and all safety decals before operating, maintaining, adjusting or unplugging the conveyor.



- Only trained, competent persons shall operate the conveyor. An untrained operator is not qualified to operate the machine.

- Have a first-aid kit available for use should the need arise.



- Provide a fire extinguisher for use in case of an accident. Store in a highly visible place.



- Do not allow riders.

- Do not allow children, spectators or bystanders within hazard area around the machine.

- Wear personal protective equipment (PPE). This list may include but is not limited to:

- Hard hat
- Protective shoes with slip resistant soles
- Eye protection
- Work gloves
- Hearing protection
- Respirator or filter mask
- Hi-Visibility safety vest

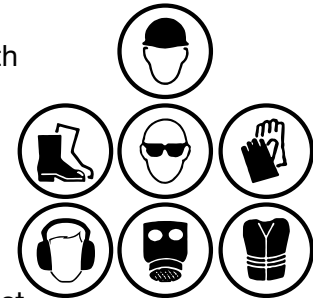

- Never use alcoholic beverages or drugs which can hinder alertness or coordination while operating this equipment.

Consult your doctor about operating this machine while taking prescription medications.

- If the elderly are assisting with farm work, their physical limitations need to be recognized and accommodated.

- Review safety related items annually with all personnel who will be operating or maintaining the conveyor.

2.3 EQUIPMENT SAFETY GUIDELINES

- Safety of the operator and bystanders is one of the main concerns when designing and developing this conveyor. However, every year many accidents occur which could have been avoided by a few seconds of thought, and a more careful approach to handling equipment.
- Do not allow personnel to operate this unit until they have read this manual. They should have a thorough understanding of the safety precautions.
- In order to provide a better view, certain images in this manual may show an assembly with safety guards removed.

Equipment should never be operated in this condition. All guards must be in place. If removal becomes necessary for repairs, replace the guard prior to use.

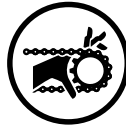

- This equipment is dangerous to children and persons unfamiliar with its operation.

The operator must be responsible, properly trained and physically able. You should be familiar with farm machinery in general.

- Never exceed the limits of a piece of machinery. If its ability to do a job, or to do so safely, is in question - DO NOT TRY IT.
- Do not modify the equipment in any way. Unauthorized modification result in serious injury or death and may impair the function and life of the equipment.
- The design and configuration of this conveyor includes safety decals and equipment. They need to be clean, readable and in good condition.

2.4 SAFETY DECALS

- Keep safety decals clean and legible at all times.
- Replace safety decals that are missing or have become illegible.
- Replaced parts must display the same decal(s) as the original parts.
- All safety decals have a part number in the lower right hand corner. Use this part number when ordering replacements.
- Safety decals are available from your authorized distributor, dealer's parts department or from Meridian Manufacturing Inc.

2.4.1 Applying Decals:

1. Be sure the application area is clean and dry. Ensure the surrounding temperature is above 10°C (50°F).
 - a. Remove all dirt, grease, wax from surface.
 - b. Clean the area with a non-ammonia based cleaner.
 - c. Wipe the clean surface with isopropyl alcohol on paper towel, and allow to dry.
2. Determine the exact position before you remove the backing paper.
3. Peel a small portion of the split backing paper.
4. Align the decal over the specified area. Use a squeegee to carefully press the small portion, with the exposed adhesive backing, into place.
5. Slowly peel back the remaining paper and carefully smooth the rest of the decal into place.
6. Small air pockets can be pierced with a pin and smoothed out using the squeegee, or a piece of sign backing paper.

2.5 DECAL LOCATION

The following illustrations show the general location of decals on this conveyor. The position of decals may vary depending on the machine's options. Decals are not shown at actual size.

- Convey-All logo on sides of tube at discharge.
- Red reflectors: on discharge spout, and discharge-side of axle.
- Amber Reflectors: on sides of hopper, at less than 15 ft intervals along tube, and on hopper-side of axle.

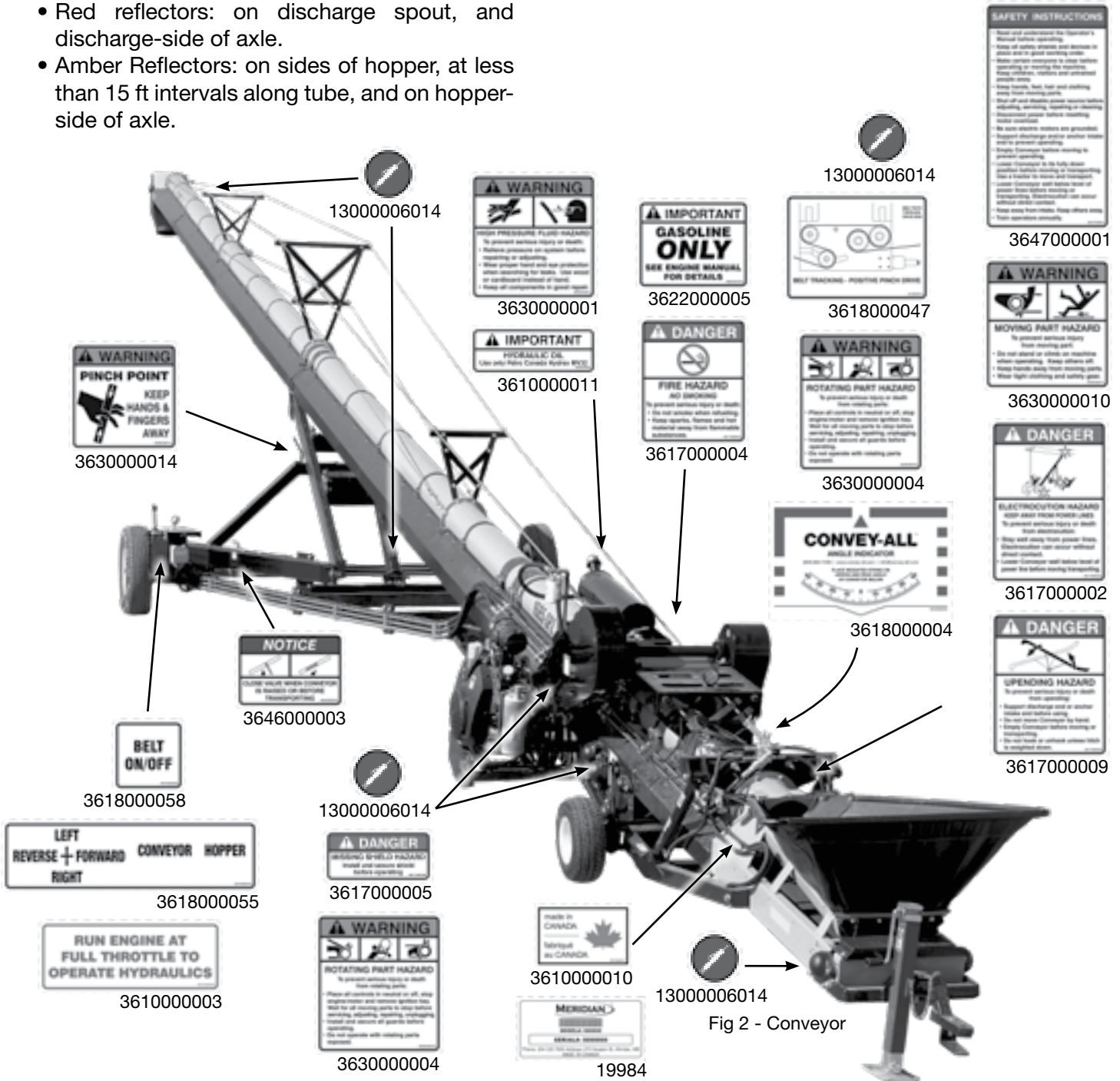

Fig 2 - Conveyor

REMEMBER - If safety decals have been damaged, removed, become illegible, or parts were replaced without signage, new ones must be applied. New decals are available from your authorized dealer.

2.6 WORK PREPARATION

- Never operate the conveyor and its engine until you have read this manual, and understand the information.

Also, read the engine operator's manual.

- Be familiar with the safety messages found on the decals around this unit.

- Personal protective equipment (PPE) include:

- Hard hat
- Eye protection
- Protective shoes
- Work gloves



They are recommended during installation, placement, operation, maintenance and removal of the equipment.

- Do not allow long hair, loose fitting clothing or jewelry to be around equipment.
- **PROLONGED EXPOSURE TO LOUD NOISE MAY CAUSE PERMANENT HEARING LOSS!**

Agricultural equipment can often be noisy enough to cause permanent, partial hearing loss. We recommend that you wear hearing protection on a full-time basis if the noise in the Operator's position exceeds 80 db.



Noise over 85 db on a long-term basis can cause severe hearing loss.

Noise over 90 db adjacent to the operator over a long-term basis may cause permanent, total hearing loss.

Note:

Hearing loss from loud noise (tractors, chain saws, radios, etc.) is cumulative over a lifetime without hope of natural recovery.

- Clear working area of stones, branches or hidden obstacles that might be hooked or snagged, causing injury or damage.
- Operate only in daylight or good artificial light.
- Be sure machine is in a stable position, is adjusted and in good operating condition.
- Ensure that all safety guards and safety decals are properly installed and in good condition.
- Before starting, inspect the unit for any loose bolts, worn parts, cracks, leaks or frayed belts. Make the necessary repairs.

Always follow the maintenance instructions.

2.7 PLACEMENT SAFETY

- Stay away from overhead power lines when operating or moving the conveyor. Electrocutation can occur without direct contact.
- Keep conveyor as low as possible.
- Chock conveyor wheels before operating.
- Position conveyor providing enough space for trucks to unload.
- Operate conveyor on level ground, free of debris.

2.8 LOCK-OUT TAG-OUT SAFETY

- Establish a formal Lock-Out Tag-Out program for your operation.
- Train all operators and service personnel before allowing them to work around the area.
- Provide tags on the machine and a sign-up sheet to record tag out details.

2.9 MAINTENANCE SAFETY

- Review Section 4: Service and Maintenance, before maintaining or operating the conveyor.
- Follow good shop practices:
 - Keep service area clean and dry.
 - Be sure electrical outlets and tools are properly grounded.
 - Use adequate light for the job.
- Place all controls in neutral or off. Stop engine, and remove ignition key. Wait for all moving parts to stop before servicing, adjusting, repairing.
- Relieve pressure from hydraulic circuit before servicing.
- Before applying pressure to a hydraulic system, ensure all components are tight and that hoses and couplings are in good condition.
- Keep hands, feet, hair, and clothing away from all moving/rotating parts.
- Replace parts with genuine factory replacements parts to restore your equipment to original specifications.



Meridian Manufacturing Inc. will not be responsible for injuries or damages caused by using unapproved parts and/or accessories.

- Make sure there is plenty of ventilation. Never operate the engine in a closed building. The exhaust fumes may cause asphyxiation.
- Clear the area of bystanders, especially children, when carrying out any maintenance and repairs or making any adjustments.
- Place stands or blocks under the frame before working beneath the machine.
- Before resuming work, install and secure all guards when maintenance work is completed.
- Replace damaged or not clearly visible decals.

2.10 TIRE SAFETY

- Failure to follow procedure when mounting a tire on a wheel or rim can produce an explosion and may result in serious injury or death.
- Do not attempt to mount a tire unless you have proper equipment and training to do the job.
- Have a qualified tire dealer or repair service perform required tire maintenance.
- When replacing worn tires, make sure they meet original tire specifications. Never undersize.
- Reference the tire side wall for information on the maximum cold tire pressure (PSI). Keep the tires inflated to this setting.





2.11 BATTERY SAFETY

- Keep all sparks and flames away from battery, as the gas given off by electrolyte is explosive.
- Avoid contact with battery electrolyte. Wash off any spilled electrolyte immediately.
- Wear safety glasses when working near batteries.
- Do not tip batteries more than 45 degrees, to avoid electrolyte loss.
- To avoid injury from spark or short circuit, disconnect battery ground cable before servicing any part of electrical system.
- When storing conveyor for an extended period:
 - Remove the battery.
 - Be sure it is fully charged.
 - Store it inside.
 - Do not sit battery on a cold, concrete floor.
- Before using the battery, after it has been in storage, be sure it is charged.



2.12 ENGINE SAFETY

- Read and understand the operating manual provided with the engine. 
- Use proper tools to service engine.
- Do not run engine in an enclosed area. Exhaust gases contain carbon monoxide, an odorless and deadly poison.
- Store fuel in approved safety containers.
- Do not store fuel near open flame. 

Appliances such as a stove, furnace, or water heater use a pilot light which can create a spark. 
- No smoking when filling fuel tank.
- Do not remove fuel cap while engine is running.
- Do not refuel indoors where area is not well ventilated. Outdoor refueling is preferred.
- Do not refuel while engine is running. Allow engine to cool for 5 minutes before proceeding.
- Use fresh fuel. Stale fuel can gum carburetor and cause leakage.
- Check fuel lines and fittings frequently for cracks or leaks. Replace if necessary.
- Do not operate engine if fuel has spilled. Move machine away. Avoid creating any ignition until the fuel has evaporated.
- Do not run engine above rated speeds. This may result in damage and injury.
- Do not tamper with the engine speed selected by the original equipment manufacturer.
- Do not operate engine with grass, leaves, dirt or other combustible materials in muffler area.
- Do not operate engine without muffler.

- Do not tamper with governor springs, governor links or other parts which may increase the governed engine speed.
- Do not strike flywheel with hard object or metal tool. This may cause it to shatter in operation.
- Keep cylinder fins/governor parts free of grass and other debris which can affect engine speed.

⚠ WARNING**HOT EQUIPMENT HAZARD**

Do not touch muffler, cylinder or fins while engine is running. Contact will cause burns.

- Do not use this engine on any forest covered, brush covered, or grass covered unimproved land, unless a spark arrester is installed on muffler. The arrester must be maintained in effective working order by operator.

In the State of California the above is required by law (Section 4442 of the California Public Resources Code). Other states may have similar laws. Federal laws apply on federal lands.

- Inspect the muffler periodically. Replace it when necessary.

If engine is equipped with a muffler deflector, inspect periodically. Replace with correct part.

- Do not check for spark, or crank engine with spark plug or spark plug wire removed.
- Do not run engine with air filter or its cover removed.

NOTICE**POSSIBLE ENGINE DAMAGE**

Decelerate engine slowly to stop.
Avoid choking carburetor to stop engine.
Choke only for an emergency stop.

2.13 OPERATING SAFETY

- Anyone who will be operating this conveyor, or working around it, must read this manual. They must know operating, maintenance, safety info.



Review the manual annually.

- Clean or replace all safety decals if they cannot be clearly read and understood.
- Place all controls in neutral, and stop the engine. Remove the ignition key. Wait for all moving parts to stop before adjusting, repairing or unplugging.
- Keep all bystanders, especially children, away from the machine when running.

Also, when authorized personnel are carrying out maintenance work.

- Establish a Lock-Out, Tag-Out policy for the work site. Be sure all personnel are trained in and follow all procedures.

Lock-out, tag-out all power sources before servicing the unit or working around equipment.

- Be familiar with machine hazard area. If anyone enters hazard areas, shut down machine immediately. Clear the area before restarting.

- Keep hands, feet, hair and clothing away from all moving/rotating parts.



- Do not allow riders on the conveyor when moving or transporting it.

- Keep working area clean and free of debris to prevent slipping/tripping.



- Stay away from overhead obstructions and power lines during operation and transporting. Electrocutation can occur without direct contact.

- Do not operate the conveyor when any guards are removed.

- Chock wheels of conveyor before starting.
- Be sure that conveyor tube is empty before raising or lowering.
- Close hydraulic lift ball valve when machine is in working position or before transporting.
- High winds may overturn conveyor. To avoid damage to structures and equipment, do not raise conveyor fully in windy conditions.

Do not leave conveyor raised, when not in use.

2.14 HYDRAULIC SAFETY

- Always place hydraulic controls in neutral. Then relieve pressure in hydraulic system before maintaining or working on machine.
- Be sure that all components in the hydraulic system are kept in good condition and are clean.
- Replace any worn, cut, abraded, flattened or crimped hoses.
- Do not attempt any makeshift repairs to the hydraulic fittings or hoses by using tape, clamps or cements. The hydraulic system operates under extremely high-pressure. Such repairs will fail suddenly and create a hazardous and unsafe condition.

- Wear proper hand and eye protection when searching for a high-pressure hydraulic leak. Use a piece of wood or cardboard as backstop instead of hand to isolate/identify a leak.



- If injured by a concentrated high-pressure stream of hydraulic fluid, seek medical attention immediately. Serious infection or toxic reaction can develop from hydraulic fluid piercing the skin surface.



2.15 WORKPLACE HAZARD AREA

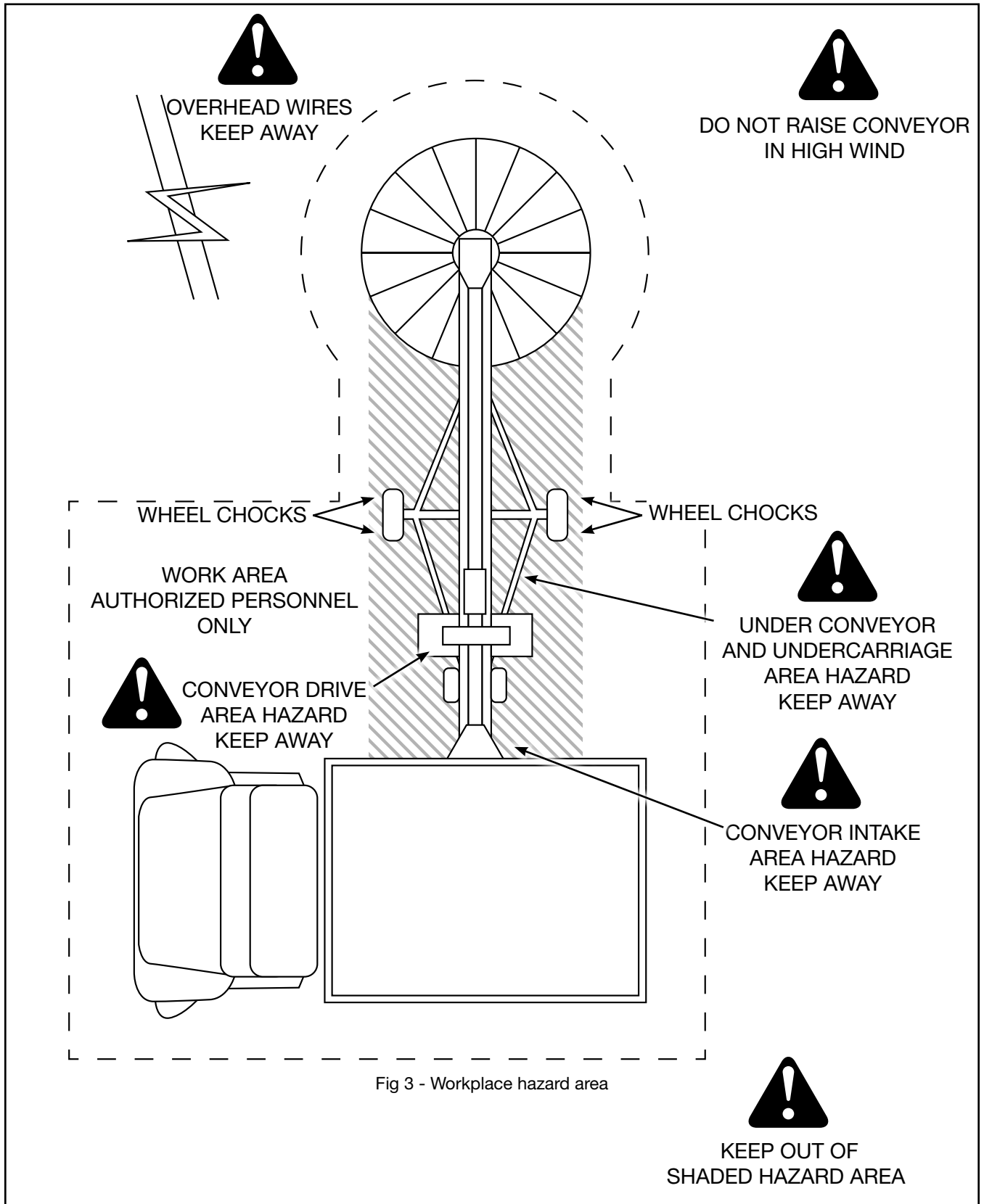

Fig 3 - Workplace hazard area

2.16 TRANSPORT SAFETY

- The conveyor belt must be empty before raising or lowering it.
- Always transport conveyor in collapsed position.
- Ensure all lights, reflectors other lighting requirements are installed and in good condition.
- Never allow riders on the conveyor.
- Comply with all local laws governing safety and transporting equipment on public roads.
- Do not exceed a safe travel speed. Slow down for rough terrain and when cornering.
- Stay away from overhead power lines. Electrocutation can occur without direct contact.
- Plan your route to avoid heavy traffic.
- Do not drink and drive.
- Be a safe and courteous driver. Always yield to oncoming traffic in all situations, including narrow bridges, intersections, etc. Watch for traffic when operating near or crossing roadways.

2.17 STORAGE SAFETY

- Store the conveyor on a firm, level surface.
- Store in an area away from human activity.
- If required, make sure the unit is solidly blocked up.
- Remove the battery and store in dry location. Do not sit on cold concrete floor.
- Make certain all mechanical locks are safely and positively connected before storing.
- Do not permit children to play on or around the stored machine.

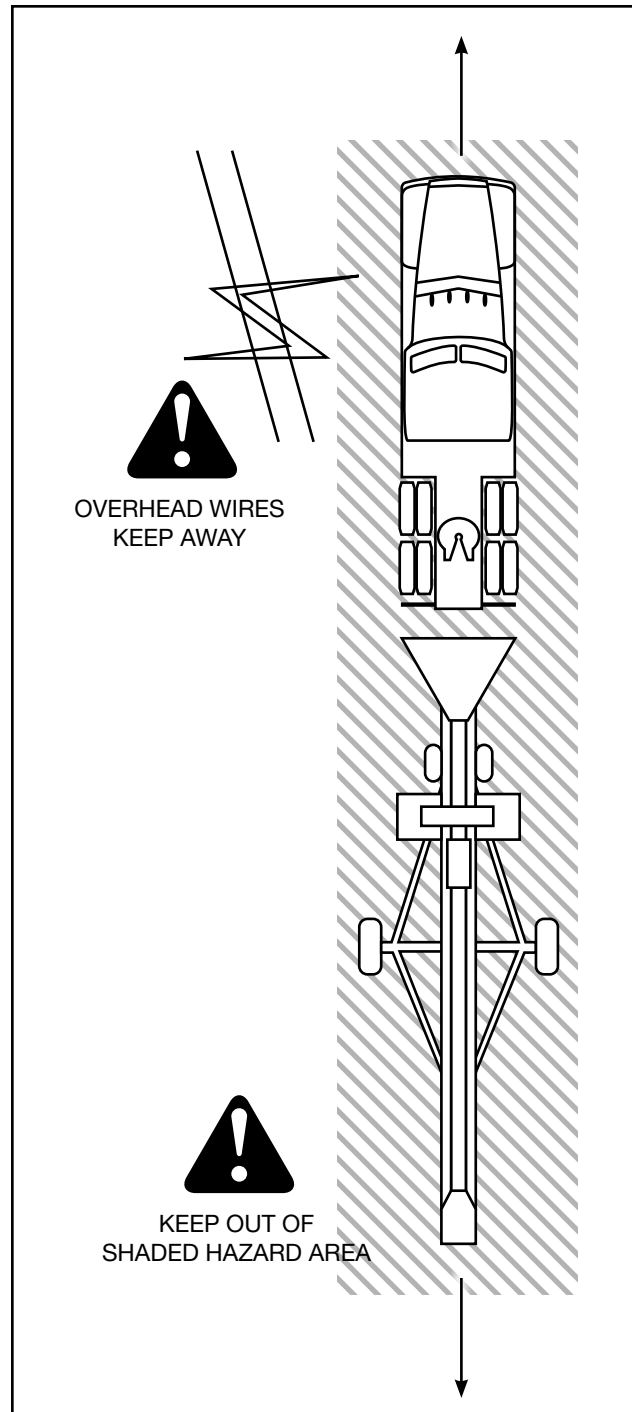

Fig 4 - Transporting hazard area

Section 3: OPERATION

WARNING

- Read and understand the Operator's Manual, and all safety decals, before using.
- Stop the engine. Place all controls in neutral, remove ignition key and wait for all moving parts to stop before servicing, adjusting, or repairing or unplugging.
- Clear the area of bystanders, especially children, before starting.
- Keep working area clean and free of debris to prevent slipping or tripping.
- Keep hands, feet, hair and clothing away from all moving and/or rotating parts.
- Do not allow riders on the conveyor when driving mover kit.
- Stay away from overhead obstructions and power lines during operation. Electrocutation can occur without direct contact.
- Do not operate conveyor with guards removed.
- Chock wheels of conveyor before starting.
- Be familiar with machine hazard area. If anyone enters hazard areas, shut down machine immediately. Clear area before restarting.
- Establish a lock-out, tag-out policy for the work site. Be sure all personnel are trained in and follow all procedures. Lock-out tag-out all power sources before servicing the unit.

The Convey-All® Bin Fill Conveyor has many features incorporated into it as a the result of suggestions made by customers like you.

Hazard controls and accident prevention are dependent upon the personnel operating and maintaining it. Their awareness, concern, prudence and proper training are crucial.

It is the responsibility of the owner and operators to read this manual and to train all personnel before they start working with the machine. By following recommended procedure, a safe working environment is provided for the operator, co-workers and bystanders in the area around the work site.

By following the operating instructions, in conjunction with a good maintenance program, your conveyor will provide many years of trouble free service.

3.1 MACHINE COMPONENTS

A gas engine supplies power to the self-contained hydraulic system.

The hydraulics is used to manoeuvre the machine and operate the conveyor belt. A hydraulic cylinder is used to raise or lower the tube.

Components may vary, and their positions may change depending on the options contained on the conveyor.

The main components are listed below:

- a. Main Tube
- b. Hopper
- c. Discharge Spout
- d. Scissor Lift Undercarriage
- e. Conveyor Belt Wind Guard
- f. Conveyor Belt Alignment and Tension Springs
- g. Gas Engine
- h. Fuel Tank
- i. Hydraulic Reservoir
- j. Hydraulic Valve Bank
- k. Drive Box
- l. Drive Belts
- m. Drive Wheels
- n. Steering Wheels
- o. Document Holder
- p. Hitch and Drawbar
- q. Jack

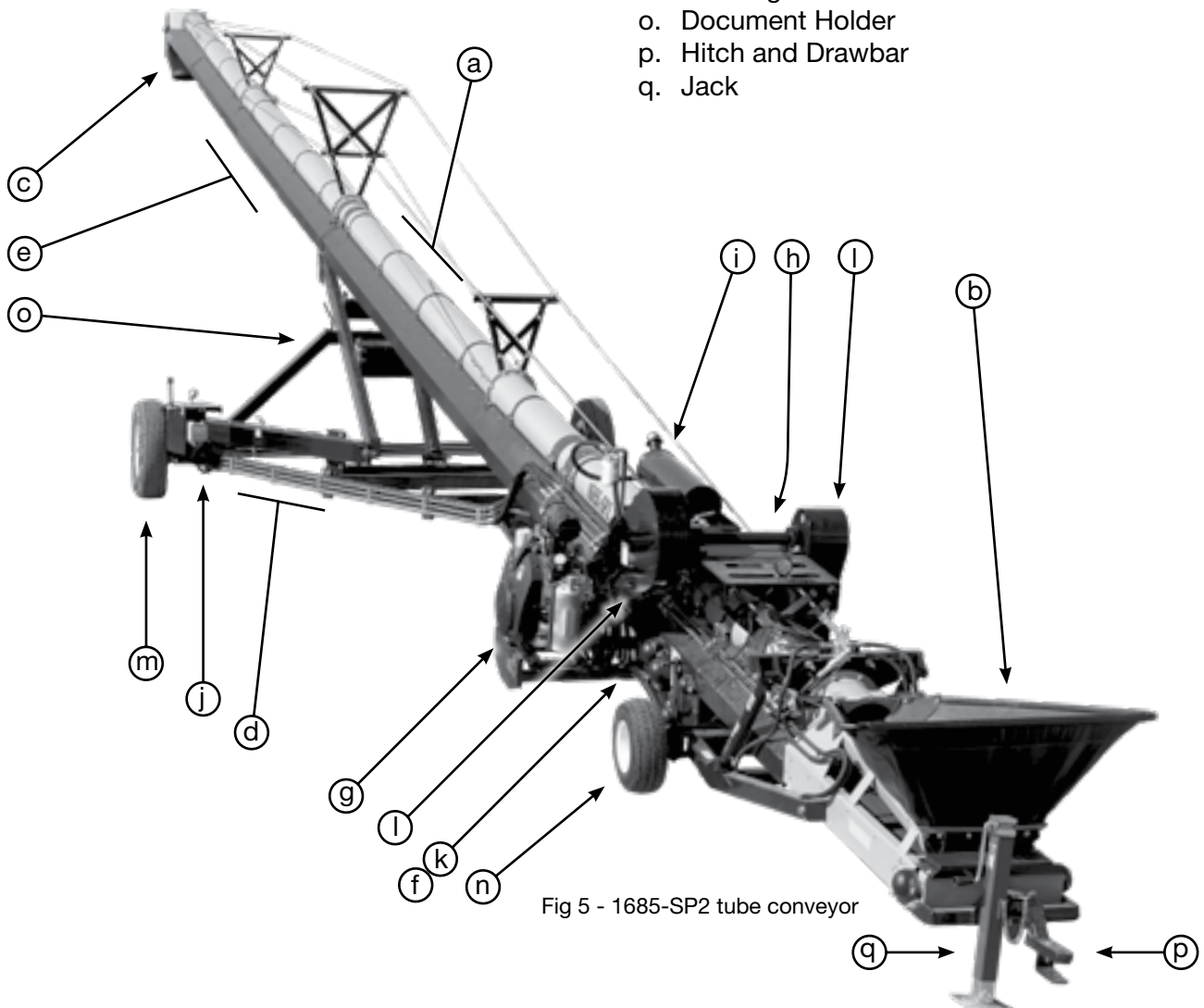

Fig 5 - 1685-SP2 tube conveyor

3.2 COMPONENTS AND CONTROLS

Before starting to work, all operators must familiarize themselves with the location and function of the components and controls of their specific unit.

Options and locations may change without notice.

Refer to the engine manufacturer's manual for more detailed information.

Engine controls may vary depending on model.

Gas Engine:

The engine is located on the cradle, which hangs off the tube, at the Hopper.

- a. Ignition Switch:
Insert the key into the engine, turn clockwise to start. Turn counterclockwise to turn OFF.
- b. Throttle:
The lever on the engine controls the RPM.

Always run at maximum engine RPM when operating the conveyor belt.

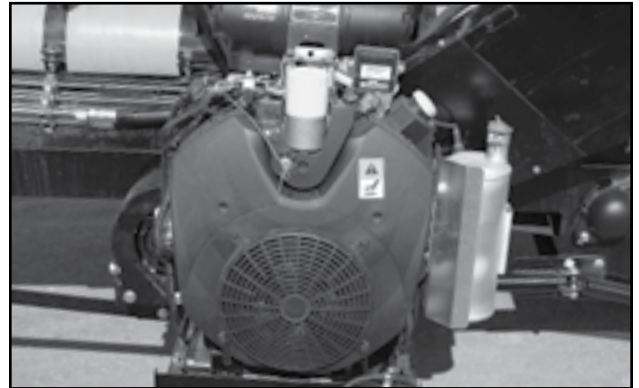

Fig 6 - Engine

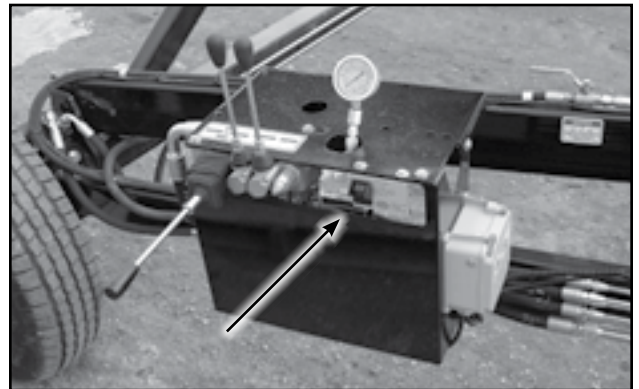

Fig 7 - Electric clutch switch

NOTICE

EQUIPMENT FAILURE POSSIBLE

Always turn off electric clutch when hydraulics are not in use. If left running, it will over heat the oil and drain electrical system.

Electric Clutch Switch:

The switch is located beside the hydraulic valves. Once the engine is running, engage the electric clutch, to run the hydraulic pump.

The electric clutch is situated behind the engine. It give power to the hydraulic pump using a V-belt.

Hydraulic Controls:

The hydraulic valve is on the right-side of the undercarriage, near the axle.

a. Mover Kit:

This 4 position, spring-loaded lever controls the movement of the conveyor. It drives the wheels forward and reverse. The lever also turns the steering wheels.

Note:

Watch wheels when holding lever.
Turn the steering wheels only as much as required.

b. Conveyor Tube Lift:

This lever controls the height of the tube.

Note:

The ball valve must be open to raise/lower the conveyor.
Close valve to lock the tube in position.

c. Hopper Lift:

This lever controls the height of the steering wheels below the hopper.

d. Hydraulic Pressure Gauge:

This gauge displays the hydraulic pressure in the machine moving and lifting circuits.

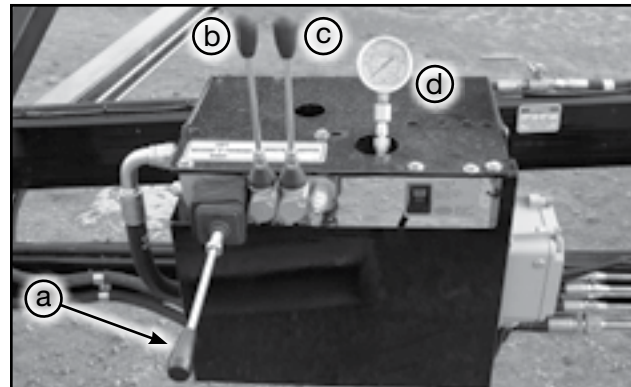

Fig 8 - Hydraulic valve

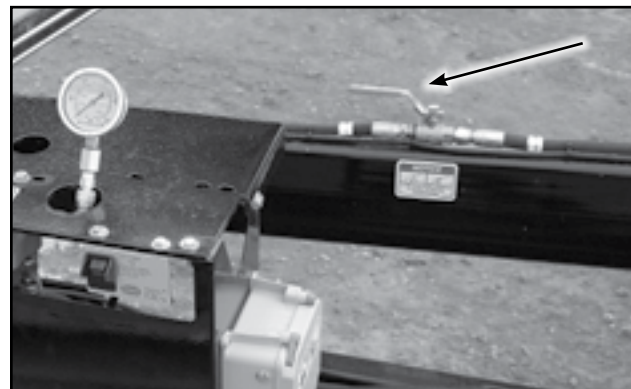

Fig 9 - Hydraulic ball valve to conveyor tube lift cylinder

Hydraulic Valve to Tube Lift Cylinder:

This valve allows oil into or out of the hydraulic cylinder that raises/lowers the tube.

IMPORTANT:

Hydraulic valve must be fully opened prior to raising/lowering tube.
Valve must be closed fully when the conveyor is positioned, to prevent the ram from moving during operation.

Hydraulic Pump:

The Hydraulic Pump is set beside the engine.

The bolts on the base are used to adjust the tension of the belt between the pump and engine.

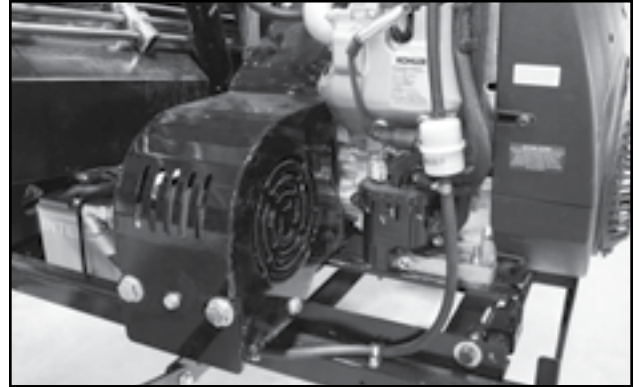

Fig 10 - Hydraulic pump

Conveyor Belt Clutch Switches:

There are 2 switches to start the clutch which operates the conveyor belt.

One is bolted to the frame below the engine.

The second switch is connected to an extension cord, and can be located where it is convenient.



Fig 11 - First conveyor belt clutch switch



Fig 12 - Second conveyor belt clutch switch

Working Light Switch:

The Light Switch is on the Junction Box, bolted to the valve cover. It powers both hopper and discharge lights.

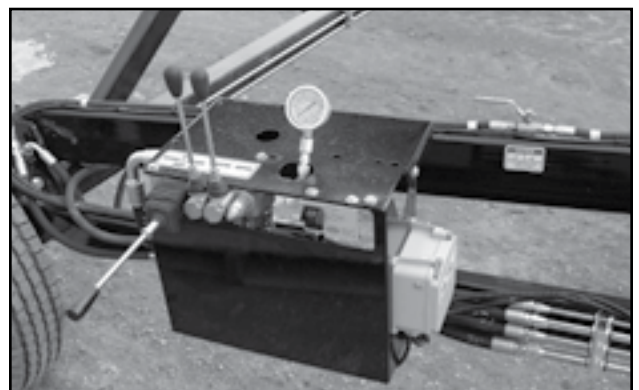

Fig 13 - Light switch

Collapsible Hopper:

Hoppers can be designed with a spring-loaded frame. This will allow the truck box to push the hopper edge down, without causing damage.

All hoppers have rubber flashing to seal the junction between the belt and the sides of the hopper.

⚠ WARNING**UNEXPECTED MOVEMENT**

Control the hopper frame at all times.
Sudden release can causing serious injury.

Hopper Clip:

The Hopper comes with a clip on the frame to hold the canvas sides down when required.

Hopper Steering Wheels:

The wheels at the hopper are steerable, and turn the unit when manoeuvring. Use the levers on the hydraulic valve bank to operate.

Hydraulic cylinders are used to raise and lower the wheels. Raising, drops the hopper to sit on the ground for unloading. Lowering the wheels, lifts the hopper, for moving the unit.

Hydraulic check valves lock the wheels, when they are raised.

IMPORTANT:

Do not extend the wheel cylinders fully.
Raising the hopper too high
may cause it to upend.



Fig 14 - Collapsible hopper

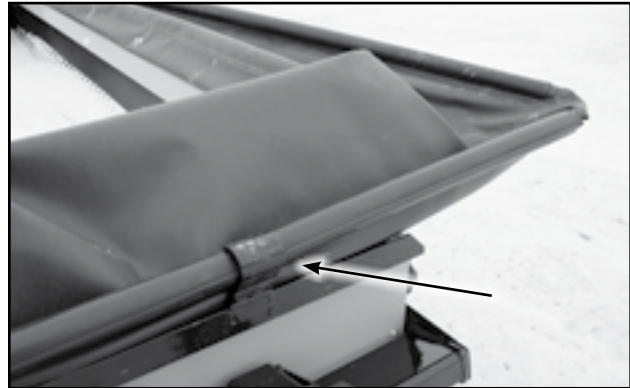

Fig 15 - Hopper clip



Fig 16 - Steering wheels

Discharge Spout:

The discharge spout is designed with six settings to position the hood at the appropriate configuration for the application.

Move the spout into one of the hole settings if the product needs to be directed further back rather than straight down.

Remove the position bracket and flip the hood back to throw the product as far as possible. This configuration works well when making piles or inside buildings.

Drive Wheels:

The wheels on the undercarriage use hydraulics to drive the conveyor unit. They have a lever to manually engage or disengage the drive mechanism. When disengaged, insert the retaining clip to secure.

NOTICE

EQUIPMENT DAMAGE LIKELY
Always disengage drive wheels before transport. Hydraulic motors will be damage if driven at highway speeds.

Working Lights:

Work lights are situated to illuminate the hopper and discharge ends of the machine. The 12 volt DC working lights make operating the conveyor at any time safe and convenient.

Use the switch on the junction box to work them.

Drawbar and Jack Storage:

There is a plate mounted to the conveyor's undercarriage. This is where the drawbar and jack can be placed for storage, when not in use.



Fig 17 - Discharge hood



Fig 18 - Drive wheel



Fig 19 - Hopper working light



Fig 20 - Storage plate

Angle of Operation Indicator:

On the drive box, is a decal to assist in calculation of operating angle.

Hold a weighted string against the arrow (above the Convey-All logo). Reference the graph and read where the string lies.



Fig 21 - Angle of Operation indicator

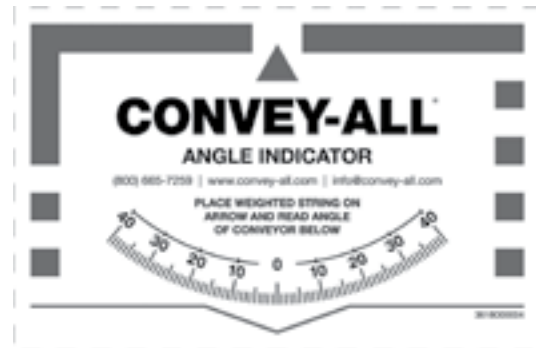

3618000004

Fig 22 - Angle of Operation decal

Cable Bridging:

This bridging needs to be adjusted periodically to keep the tube straight. Refer to page 4-7.



Fig 23 - Cable bridging

3.3 MACHINE BREAK-IN

There are no operational restrictions on the conveyor when used for the first time.

The conveyor belt alignment is set at the factory, to track correctly without carrying a load.

Before Starting Work:

1. Read conveyor and engine operator manuals.
2. Run the unit for half an hour to seat the conveyor belt and hopper flashing. It is normal for rubber from the flashing to be expelled out the discharge and form a pattern on the belt.

After Operating for 1/2 hour:

3. Re-torque all wheel bolts, fasteners, hardware.
4. Check fuel, engine oil and hydraulic oil levels.
5. During the conveyors first few minutes of operation, check belt alignment to ensure preset alignment and tension does not vary under loaded conditions.
6. Check the flashing seal on the hopper. If any product leaks from the hopper, around the flashing, stop the belt, loosen flashing mounting screws and adjust. Retighten anchor screws and try again. Repeat until no product is lost.
7. Check the condition of all hydraulic lines, hoses and connections. Repair or replace any damaged system components.
8. Check that all guards are installed and function as intended.

After Operating For 5 Hours and 10 Hours:

Repeat steps 1 through 8 above.

Service and maintain the unit as per Section 4.

3.4 PRE-OPERATION CHECKLIST

Efficient and safe operation of the conveyor requires that each operator knows the operating procedures.

It is important for both the personal safety and maintaining the good mechanical condition of the conveyor that this checklist is followed.

Before operating the conveyor, and each time thereafter, check the following areas:

1. Check worksite. Clean up working area to prevent slipping or tripping.
2. Be sure that the battery is fully charged, If needed, charge the battery before connecting it with the battery cables.
3. Lubricate and service the machine as per the schedule outlined in Section 4.2.
4. Check that all guards are installed, secured and functioning as intended. Do not operate with missing or damaged shields.
5. Check that the belt is properly tensioned and aligned. Ensure it is not frayed or damaged. Refer to Section 4.3.1 and 4.3.2
6. Check the drive belt tension and alignment. Refer to Section 4.3.4 and 4.3.5
7. Be sure conveyor's wheels are chocked.
8. Check that the discharge and intake hopper areas are free of obstructions.

NOTICE

UPENDING HAZARD

Anchoring or support conveyor during operation. When the lower half empties of product, the weight balance transfers to the discharge end of the machine, which can cause upending.

3.5 ATTACHING TO TOW VEHICLE**⚠ DANGER****ELECTROCUTION HAZARD**

Ensure enough clearance from overhead obstructions, power lines or other equipment.

1. Clear the working area of bystanders, especially small children.

IMPORTANT:

Before starting conveyor engine, ensure electric clutch is off.

2. If the conveyor is above a storage facility:
 - Start the engine.
 - Raise the conveyor tube so the discharge spout clears the structure.
 - Manoeuvre the conveyor away from the bin.
 - Lower the tube to its collapsed position.
3. Ensure there is sufficient room and clearance to move the conveyor away, and to move the tow vehicle into position.

NOTICE**UPENDING HAZARD**

The machine is closely balanced. Do not lift unless there is downward weight on the hopper end to prevent upending.

4. Attach the jack and use it to raise the hopper.
 - or -
 Start the engine, and lower the steering wheels to raise the hopper.
5. Install the drawbar on the hitch.
 - Secure it with anchor pin and retainer clip.

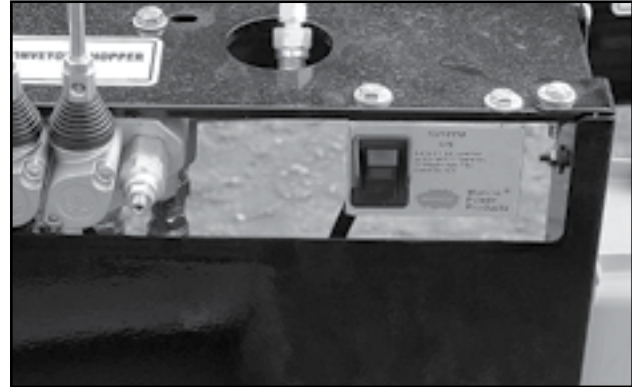

Fig 24 - Electric clutch switch

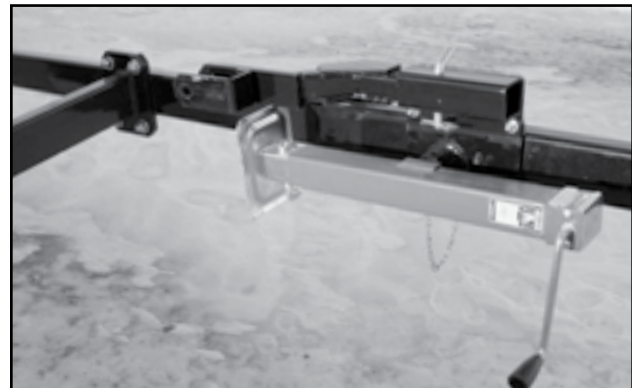

Fig 26 - Jack and drawbar in storage

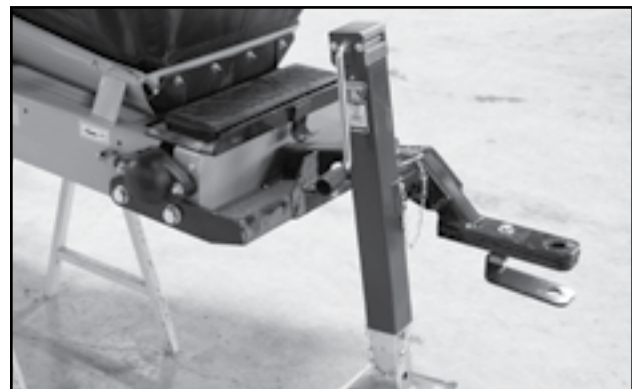

Fig 25 - Drawbar and Jack

6. Align the tow vehicle's hitch with the drawbar of the conveyor while backing up.
 - Set the park brake before dismounting the tow vehicle.
7. Connect the pin with its retainer clip, to connect the tow vehicle.
8. Secure the safety chain around the drawbar cage to prevent unexpected separation.
9. Raise the steering wheels.
10. Remove and store the jack.
11. Turn off the conveyor's engine.

NOTICE

EQUIPMENT DAMAGE LIKELY
Always disengage drive wheels before transport. Hydraulic motors will be damage if driven at highway speeds.

12. Disengage wheel drive assemblies on both wheels. Secure with a retainer clip.
13. Before transporting, refer to Section 3.9.



Fig 27 - Attached to tow vehicle

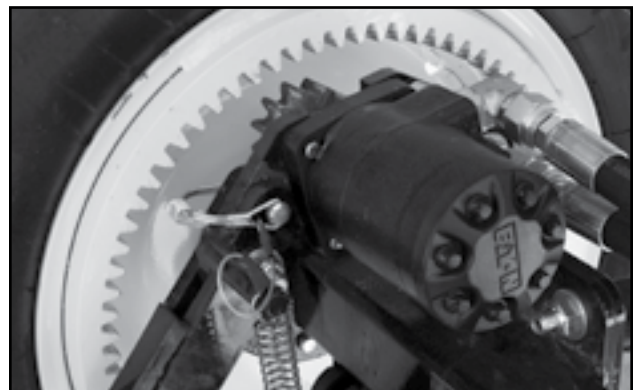

Fig 28 - Disengaged drive wheel

3.6 CONVEYOR PLACEMENT

Follow this procedure when placing the conveyor into its working position:

1. Clear the area of bystanders, especially small children, before starting.
2. Transport the conveyor to the working area.
3. Attach the jack. Use it to support the hopper.
- or -
Start the engine, and lower the steering wheels to support the hopper.
4. Detach the conveyor from the tow vehicle.

⚠ CAUTION

SAFETY HAZARD

Remove jack and drawbar to prevent interference and clear a tripping hazard.

5. If not done before, start the conveyor's engine, and lower the steering wheels.
6. Remove the jack and drawbar from conveyor to prevent tripping over them.

⚠ DANGER

ELECTROCUTION HAZARD

Ensure enough clearance from overhead obstructions, power lines or other equipment.

7. Remove the retainer clip, then engage the drive wheels on the conveyor's mover kit.

IMPORTANT:

Before engine start, ensure electric clutch is turned off.

8. Start the engine.



Fig 29 - Engaged drive wheels



Fig 30 - Steering wheels

9. Turn on electric clutch, start hydraulic pump.
10. Lower the steering wheels.
11. Drive the conveyor up to the storage facility.
12. Use hydraulics to raise the conveyor tube.

13. Advance until the conveyor is in position:
 - Discharge spout is above bin or structure.
 - or -
 - The conveyor hopper is in position below the bin/hopper.
14. Raise the steering wheels, to lower the hopper to the ground.
15. Lower the discharge spout into final working position.

IMPORTANT:

To prevent damage to tube and belt, be sure it does not rest on any structure.

16. Chocks the drive wheels.

NOTICE**UPENDING HAZARD**

Always weigh down of the hopper end to prevent upending.

17. Stake or weigh down the hopper end to prevent upending when machine is emptying.
18. Close the hydraulic valve to lock conveyor tube in position.

NOTICE**HIGH WIND HAZARD**

Do not operate or leave conveyor fully raised in high winds. It may blow over damaging structures and equipment.



Fig 31 - Spout in position



Fig 32 - Hopper on the ground



Fig 33 - Chock wheels

3.7 OPERATING ON SITE

When operating the conveyor, follow this procedure:

1. Clear the area of bystanders, especially small children, before starting.
2. Review the Pre-Operation Checklist before starting. Refer to Section 3.4
3. Review the Workplace Hazard Area in Section 2.15 and use extra care when inside the hazard area.

Should spectators and bystanders enter this area, stop the machine immediately.

4. Check that all guards are in place and working as intended.
5. Back truck/tender into position for unloading.

NOTICE

HIGH WIND HAZARD

Do not operate or leave conveyor fully raised in high winds. It may blow over damaging structures and equipment.

3.7.1 Starting Conveyor:

IMPORTANT:

Before engine start, be sure electric clutch is turned off.

1. Move throttle to the idle position.
2. Close the choke if the engine is cold or if the unit has not been run for a while.
3. Turn the ignition key to start the engine.
4. Run for 2-3 minutes to allow engine to warm.
5. Flip the switch to start the electric clutch.
6. Turn on conveyor belt using control switch.
7. Increase engine speed to full throttle.
8. Start flow of product, unloading into hopper.

3.7.2 Stopping Conveyor:

9. Stop unloading. Wait for the conveyor belt to empty.
10. Switch off the conveyor belt.
11. Move the throttle to idle position.
12. Turn off electric clutch.
13. Turn off engine and remove ignition key.

3.7.3 Emergency Stopping:

Although it is recommended that the tube be emptied before stopping, in an emergency situation, stop or shut-down the engine immediately.

See to the emergency.

Correct the situation before resuming work.

3.7.4 Restarting after Emergency Stop:

When the machine is shut down inadvertently or in an emergency, the conveyor belt will still be covered with product.

Since start-up torque loads are much higher than normal when belt is full, restart at a low engine speed.

Remove as much product from the hopper as possible.

It may be necessary to tighten the drive belt slightly to handle the heavier than normal loads.

3.7.5 Unplugging:

In unusual moisture, crop or product conditions, the machine can plug. When unplugging, follow this procedure:

1. Switch off conveyor belt.
2. Turn off electric clutch. Stop engine, and wait for all belts to stop rotating.
3. Lock-out, tag-out the controls.
4. Remove product from discharge and hopper area.
5. Reposition unit if discharge area plugs due to lack of clearance.

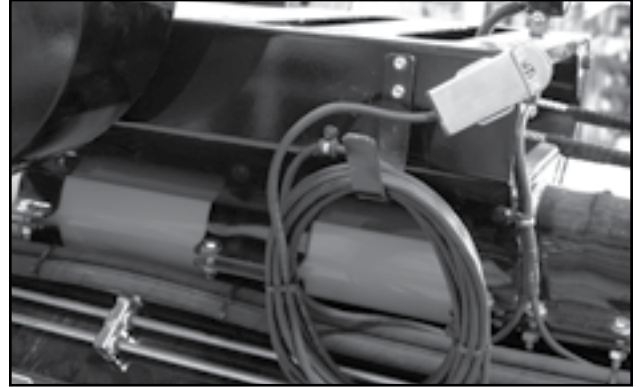

Fig 34 - Conveyor belt control switch



Fig 35 - Working conveyor



Fig 36 - Working conveyor

3.8 OPERATING HINTS:

- Keep the hopper full for maximum capacity. Most efficient results will be obtained when flow of incoming product is directed to the front (closer to the tube) of the hopper.
- Always listen for any unusual sounds or noises. If any are heard, stop the machine and determine the source. Correct the problem before resuming work.
- Do not run the machine for long periods of time with no product on the belting. This increases the wear. Try to run only when moving product.
- Do not support discharge end directly on the storage facility.
- Stake the hopper or weigh it down to prevent upending.
- For better performance, use a transfer conveyor or drive over conveyor, to move product from the storage facility or truck to conveyor hopper.
- The hopper is designed with flashing to seal the junction of the belt with the sides of the hopper.

It must be kept in good condition to prevent the product from "leaking" out of the hopper. Replace flashing if "leakage" occurs.

- **Belt Speed:**
The best results are obtained when the drive is set to provide a belt speed of 600 ft./min.

Count the number of belt revolutions per unit time to determine belt speed. Use the belt lacing as a reference when counting belt revolutions.

Contact your dealer or the factory for the appropriate drive components to give the recommended belt speed.

- **Belt Tension:**
There may be a rapid decrease in belt tension during the first few hours of operation until the belt has worn in.

The correct operating tension is the lowest tension at which the belt will not slip under peak load conditions.

- **Operating Angle:**
The hydraulic lift can set the tube angle at any position between 12° and 35° when operating.

Because the belt does not have roll-back barriers, the product will roll-back if the angle is too steep. Do not position at more than 35°.

Note:

The lower the angle,
the greater the capacity.



Fig 37 - Full hopper

3.9 TRANSPORTATION

Convey-All® conveyors are designed to be conveniently moved from place to place.

When transporting the unit, follow this procedure:

1. Refer to Section 3.5 to attach conveyor to tow vehicle.

NOTICE

EQUIPMENT Damage Likely
Always disengage drive wheels before transport. Hydraulic motors will be damage if driven at highway speeds.

2. Ensure the conveyor is ready for transport:
 - It is in fully collapsed position.
 - Drive wheels are disengaged.
 - Drawbar is attached using anchor pin, retainer and secured with the safety chain.
3. Close hydraulic valve to the lift cylinder.
4. Raise the jack. Remove and store it.
5. If equipped with transport lights, connect the wiring harness across the hitch.
 - Secure with clips, zip ties or tape. Provide slack for turning.
6. Remove chocks from around drive wheels.



Fig 38 - Collapsed position

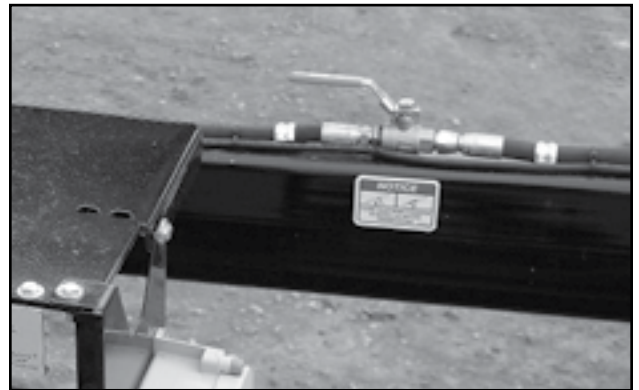

Fig 39 - Hydraulic valve to Lift cylinder



Fig 40 - Disengaged drive wheels



Fig 41 - Hitched to truck

7. Ensure the SMV (Slow Moving Vehicle) emblem, all lights and reflectors required by local highway and transport authorities are in place.

They must be clean and clearly visible by all overtaking and oncoming traffic.

8. Do not allow riders on the conveyor.
9. Slowly pull away from the working area. Be sure everything is connected and nothing is hanging.
10. Keep to the right and yield the right-of-way to allow faster traffic to pass. Drive on the road shoulder, if permitted by law.
11. Never travel across slopes of more than 20°. It is better to go straight up and down.
12. It is not recommended that the machine be transported faster than 80km/h (50mph).
13. During periods of limited visibility, use pilot vehicles or add extra lights to the machine.
14. Always use hazard flashers on the tractor when transporting unless prohibited by law.



Fig 42 - Drawbar and Jack Storage Plate



Fig 43 - Remove Chocks

3.10 STORAGE

After the season's use, or when the conveyor will not be used for an extended time, it should be inspected and prepared for storage.

Repair or replace any worn or damaged components. This will prevent any unnecessary down time at the start of next season.

To have a long, trouble free life, follow this procedure to preparing the unit for storage:

1. Remove all left over product from the hopper and the tube.
2. Inspect all moving or rotating parts and remove anything which has become entangled.

Remove the entangled material.

3. Wash the entire machine thoroughly using a water hose or pressure washer, to remove all dirt, mud, debris or residue.
 - Wash on top and under the conveyor belt.
 - Clean inside the tube.
4. Inspect all hydraulic hoses, fittings, lines, couplers and valves.
 - Tighten any loose fittings.
 - Replace any hose that is badly cut, nicked, abraded or is separating from the crimped end of the fitting.
5. Lubricate all grease fittings.
Refer to Section 4.2
 - Ensure all grease cavities have been filled with grease, to remove any water residue from the washing. This also protects the bearing seals.
6. Check the condition of the conveyor belt.
 - Replace if necessary.
7. Remove the battery.
 - Be sure it is fully charged.
 - Store it inside.
 - Do not sit battery on a cold concrete floor.

8. Touch up all paint nicks and scratches to prevent rusting.
9. Select a storage area that is dry, level and free of debris.
 - If the machine cannot be placed inside, cover the engine with a waterproof tarpaulin and tie securely in place.
10. Store the unit in an area away from human activity.
11. Remove ignition key, and store in a secure location.
12. Do not allow children to play on or around the stored machine.

IMPORTANT:

If the conveyor has been stored for more than 6 months, run the engine for 2-3 minutes. Then change the oil, while still warm, to remove any condensation.



Fig 44 - Collapsed Position

This page intentionally left blank

Section 4: SERVICE AND MAINTENANCE

WARNING

- Review the Operator's Manual and all safety items before maintaining the conveyor.
- Clear the area of bystanders, especially children, before repairing or adjusting.
- Before servicing, repairing or unplugging; place controls in neutral, stop engine, remove ignition key and wait for moving parts to stop.
- Follow good shop practices:
 - Keep service area clean and dry.
 - Be sure electrical outlets and tools are properly grounded.
 - Use adequate light for the job at hand.
- Relieve pressure from the hydraulic circuit before servicing.
- Before applying pressure to a hydraulic system, make sure all components are tight, hoses and couplings are in good condition.
- Keep hands, feet, hair and clothing away from all moving and/or rotating parts.
- Make sure there is plenty of ventilation. Never operate the engine in a closed building. The exhaust fumes may cause asphyxiation.
- Place stands or blocks under frame before working beneath the unit.
- When maintenance is complete, before resuming work, install and secure all guards.
- Keep decals clean, replace if not readable.

By following the operating instructions, in conjunction with a good maintenance program, your tube conveyor will provide many years of trouble free service.

4.1 FLUIDS AND LUBRICANTS

Fuel and Engine Oil:

Refer to the engine's operator manual for specific information.

Fuel tank capacity is 57 Litres (15 US Gal.)

Grease:

Use an SAE multipurpose high temperature grease with extreme pressure (EP) performance. Also acceptable, SAE multipurpose lithium based grease.

Hydraulic Oil:

Use an ISO grade 36 hydraulic oil for all operating conditions (Hydrex MV36 or comparable).

Oil reservoir capacity is: 25 Litres (6.25 US Gal.)

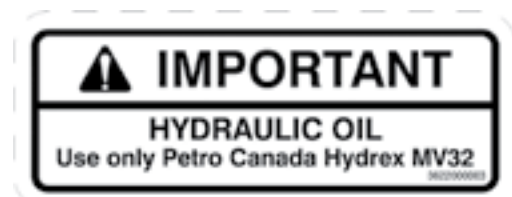

3622000003

Fig 45 - Hydraulic Oil decal

Storing Lubricants:

Your machine can operate at top efficiency only if clean lubricants are used. Use clean containers to handle all lubricants.

Store them in an area protected from dust, moisture and other contaminants.

4.1.1 Greasing:**NOTICE****GREASING HAZARD**

Too much grease causes excessive overheating. Under-greasing accelerates equipment wear.

No grease should be seen around bearings. If there is, too much grease was applied and the seal has ruptured!

IMPORTANT:

Grease bearings only one pump per month under normal usage conditions.

Bearing greasing frequency should be determined by usage and conditions.

1. Use a hand-held grease gun for all greasing.
2. Wipe grease fitting with a clean cloth before greasing, to avoid injecting dirt and grit.
3. All bearings are greasable, but require only minimal grease.

Recommended greasing is one small stroke every month. Be careful not to over-grease as this may push the seal out.

4. Replace and repair broken fittings immediately.
5. If fittings will not take grease, remove and clean thoroughly. Also clean lubricant passageway. Replace fitting if necessary.

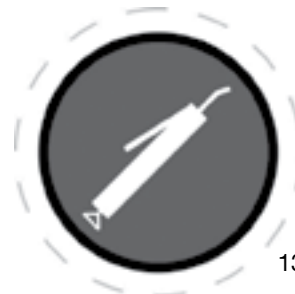

13000006014

Fig 46 - Lubricate decal

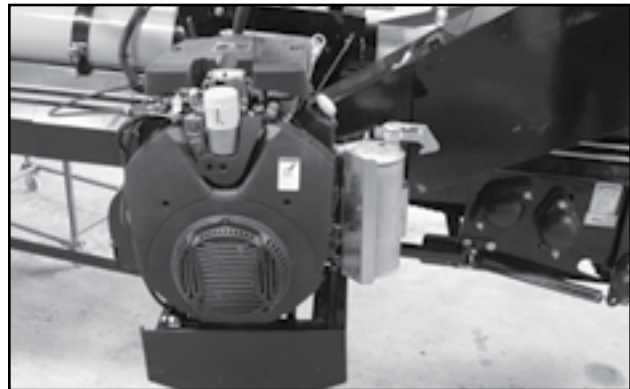

Fig 47 - Gas engine

4.2 SERVICING INTERVALS

Use the Service Record provided on page 4-19 to keep a record of all scheduled maintenance.

The conveyor belt alignment is preset to run true under a condition of no load. It is important to check alignment and make adjustments, if required, during the initial few minutes of loaded operation.

Check bearings for wear daily.

The following recommended periods are based on normal operating conditions. Severe or unusual conditions may require more frequent lubrication and oil changes.

Schedules may vary depending on options and engine model contained on your equipment.

IMPORTANT:

For engine servicing and maintenance, refer to it's manual for complete details.

4.2.1 Every 10 Hours or Daily:

1. Check fuel level.
 - Add as required.
2. Check oil level in hydraulic reservoir.
 - Add as required.
3. Inspect conveyor belt lacing for wear.
4. Check the conveyor belt tension daily while breaking-in the conveyor.
 - Refer to Section 4.2.2
5. Check the conveyor belt alignment frequently during the first 10 hours of operation until it seats itself. Refer to Section 4.2.2
6. Inspect all rollers and bearings for play and wear.
 - Replace if necessary.

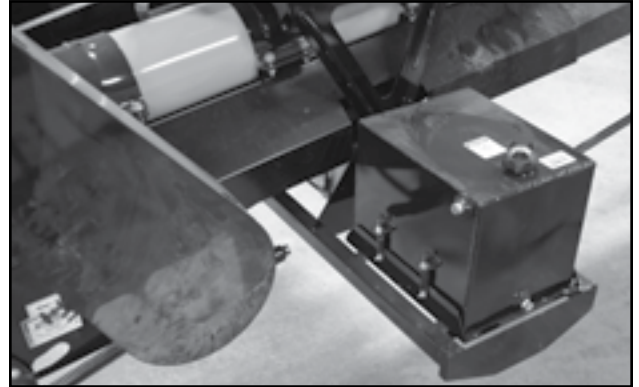

Fig 48 - Fuel tank

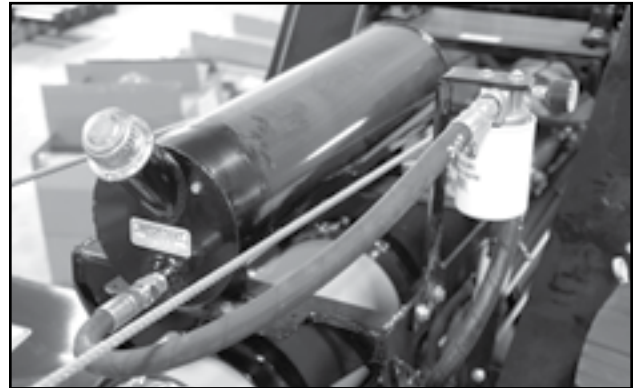

Fig 49 - Hydraulic reservoir

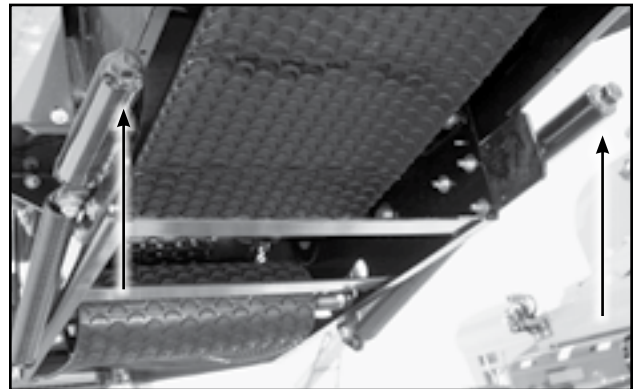

Fig 50 - Tension bolt, positive pinch drive

4.2.2 Every 50 Hours or Weekly:

7. Check the conveyor belt tension.

Watch the tension more often while breaking-in the conveyor, because the belt may stretch. Refer to Section 4.3.1

Note:

A properly tensioned belt will not slip when in operation.

8. Check the conveyor belt alignment.

- The belt alignment to the rollers must be checked at the hopper, at the drive box and the discharge.

Watch the alignment more frequently during the first 10 hours of operation. It usually seats itself and can be checked weekly after that. Refer to Section 4.3.2

9. Check drive belt tension.
Refer to Section 4.3.410. Check pulley alignment.
Refer to Section 4.3.5

11. Check the condition of the rubber, hopper flashing. Be sure it still seals the hopper to prevent leaking.

If any product comes out of the hopper around the flashing, loosen flashing mounting screws and adjust. Retighten anchor screws and try running the conveyor again. Repeat until no grain is lost.

If the flashing is stuck to the belt, manually peel the flashing up and off the hopper. Replace it if necessary.

12. Inspect the sprockets on the drive wheels, for wearing teeth.

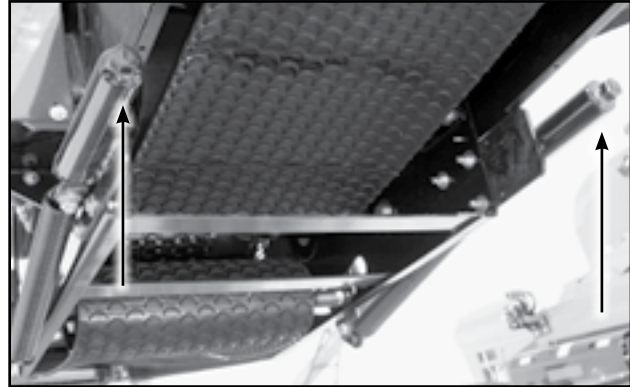

Fig 51 - Tension bolt, positive pinch drive



Fig 52 - Adjustment bolts on hopper



Fig 53 - Engine to counter shaft belt



Fig 54 - Counter shaft to drive belt

4.2.3 Every 100 Hours or Monthly:

Note:

Recommended greasing is one small stroke every month. Be careful not to over grease as this may push the seal out.

13. Grease hopper roller bearings.

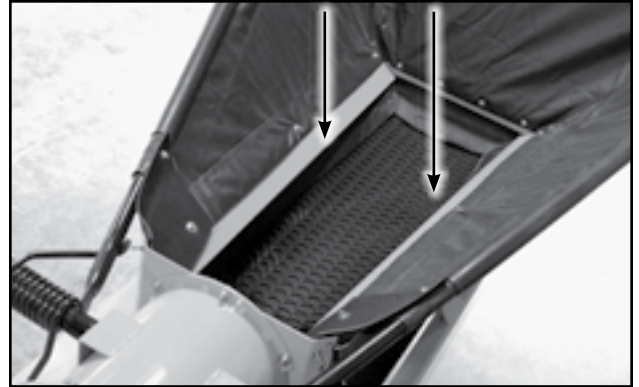

Fig 55 - Hopper flashing

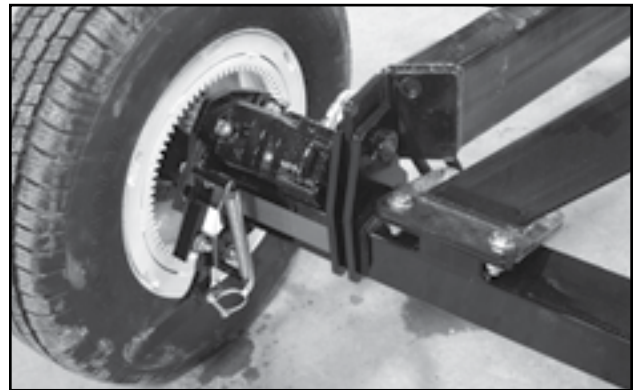

Fig 56 - Hydraulic motor, drive wheel

14. Grease counter shaft bearings.

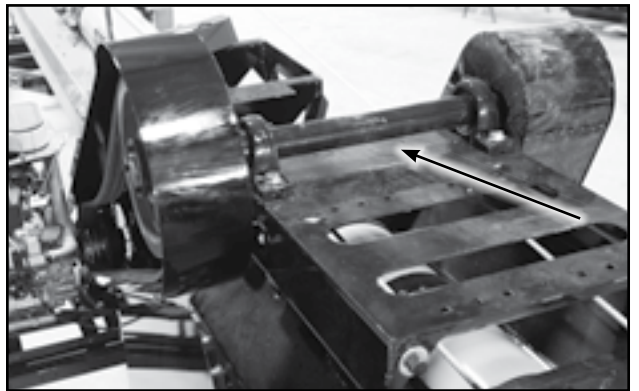

Fig 57 - Counter shaft

15. Grease drive box assembly bearings.

16. Grease discharge roller bearings.



Fig 58 - Drive box bearings

4.2.4 Every 200 Hours or Annually:

17. Refer to the engine manual for specific service and maintenance schedules.

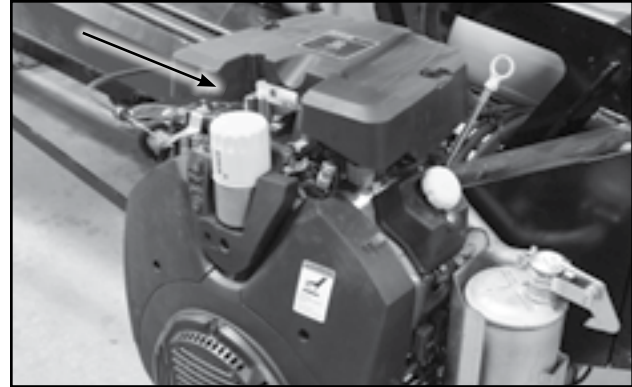

Fig 59 - Gas engine

18. Take a hydraulic oil sample and send it to a lab for particle count analysis.
- Change oil if necessary.

19. Change the hydraulic oil filter.



Fig 60 - Hydraulic system filter

21. Grease the steering wheel axle bushings.



Fig 61 - Steering wheel axle bushing

22. Grease the steering wheel lift cylinders.



Fig 62 - Steering wheel lift cylinders

23. Grease the conveyor tube lift cylinder.



Fig 63 - Steering wheel lift cylinder

24. Check the tube's straightness, horizontally and vertically.

If adjustment is necessary:

- Take tension off the cables by supporting the tube.

Note:

A thin strap can be fed between the tube and windguard, around the bottom of the tube and out the other side.

Then, it can be supported by a winch or forklift.

- Adjust eyebolts at the hopper end.
- Remove support from the tube to view the result of the adjustment.
- Repeat process until the tube is straight.



Fig 64 - Straight tube

25. Repack wheel bearings.



Fig 65 - Cable bridging eye bolts

26. Wash the entire machine thoroughly using a water hose or pressure washer to remove all dirt, mud, debris or residue.

- Wash the outside.
- Wash around the hopper.
- Leave the belt running while washing inside the tube and around the belt.



Fig 66 - Clean conveyor

4.3 MAINTENANCE PROCEDURES

By following a careful service and maintenance program for your machine, you will enjoy many years of trouble-free service.

Note:

Refer to the engine manual for complete details on your particular model.

⚠ WARNING

ROTATING BELT HAZARD

Turn off engine, lock-out power and wait for all components to stop moving before adjusting the belt.

To check belt position, Idle the engine, then rotate the belt slowly.

4.3.1 Conveyor Belt Tension:

The tension of the belt should be checked weekly, or more often if required, to be sure that it does not slip.

Use the drive box tension bolts to adjust the belt.

Note:

If belt needs more or less slack, stop belt, and turn off engine. Move hopper roller 1/4 to 1/2 inch. Tension the belt at drive box.

IMPORTANT:

If tensioning the belt while it is running, adjust in small increments, alternating between the two bolts often. This will keep the belt aligned.

This conveyor has a Positive Pinch Drive.

When loading on the belt gets heavier, the pinch roller tightens against the drive roller in proportion which provides more torque.

Tighten the tension bolts completely.

When the conveyor belt is tensioned correctly, the arm at the end of the spring should sit vertical. It can also be angled back, away from the tension bolts by as much as 2 inches. This indicates that the belt is well adjusted and is a good length.

The arm should never be angled towards the tension bolts. This would indicate that the belt is too long. Measure the angle:

- For example, if the belt angles towards the tension bolt by 2 inches (away from vertical):
 - Cut the belt 4 inches shorter. (double the 2" measurement)
 - Re-lace it.
 - Tension the belt again.

If the arm touches the far edge (away from the tension bolt), the belt is too short. Remove and replace it with a longer belt.

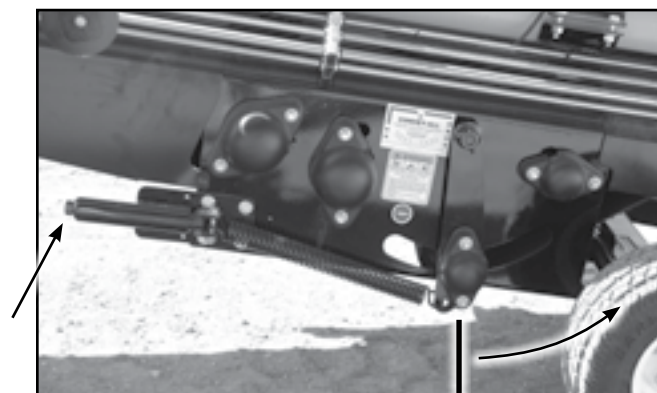

Fig 67 - Tension bolt and Belt Length Indicator

4.3.2 Conveyor Belt Alignment:**NOTICE****BELT DAMAGE HAZARD**

Belt alignment must be checked at the hopper, drive box and discharge. Inspect weekly. Unaligned belt will cause damage and void warranty.

NOTICE**BEARING FAILURE HAZARD**

If a roller is replaced, ensure both ends are evenly aligned with the frame before running. If not, bearing failure may occur.

The belt is properly aligned when it runs in the centre of all rollers. As with tensioning, the alignment should be checked weekly, or more frequent necessary.

⚠ WARNING**ROTATING BELT HAZARD**

Idle the engine, then rotate the belt slowly when checking alignment.

Turn off engine when adjusting rollers.

1. Ensure the Workplace Hazard Area is clear.
 - Refer to Section 2.15

Belt Alignment at Tail Roller:

2. Rotate the conveyor belt slowly, and check the position of the belt on the tail roller.

Note:

If belt is out of alignment, it will move to the loose side. Tighten loose side or loosen tight side.

3. Adjust one side of roller at a time.
 - Loosen bearing housing, then adjust bolt.
4. Tighten the tail roller bearing housing.
5. Rotate the conveyor belt slowly, and check the position of the belt on the hopper roller.
 - Repeat steps until the belt is centred.
6. Replace housing guard.

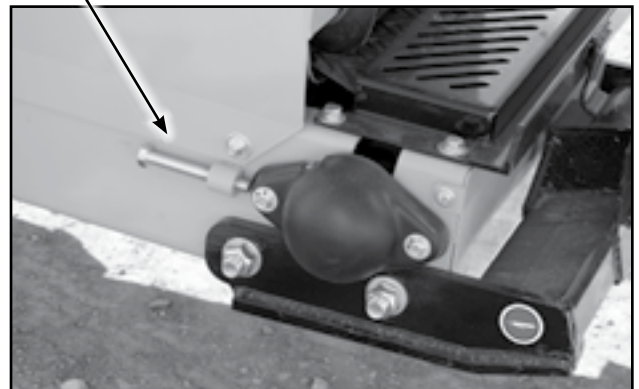

Fig 68 - Adjustment bolt on side of hopper

Belt Alignment inside Drive Box:

Aligning the belt, so it tracks down in the centre of the drive roller, is counter-intuitive. It is opposite from aligning the end rollers.

This time you must loosen the loose side.

This is because the first roller to have contact with the belt is the pinch roller, but the drive roller (second in line) is the only one which can be adjusted.

7. Loosen the drive roller bearing housing on the loose side of the belt.
8. Use the adjustment bolts at the front of the drive box to move the brackets connected to the drive roller.
9. The misaligned belt will travel towards the loose side of the roller.
 - Loosen the loose side, more.
10. Tighten the bearing housing.
11. Run the belt to check it's alignment.
 - Repeat steps if necessary.
12. Replace the housing guard.

Belt Alignment at Discharge Roller:

13. Stop the belt and turn off the engine.
14. If necessary, remove the discharge spout to view the roller.

Note:

If belt is out of alignment,
it will move to the loose side.

Tighten loose side or loosen tight side.

15. Adjust one side of roller at a time.
 - Loosen the bearing housing, then adjust.

16. Tighten the discharge roller bearing housing.
17. Run the belt a couple of revolutions and check the alignment.
 - Repeat steps until the belt runs centred.
18. Replace bearing guard.

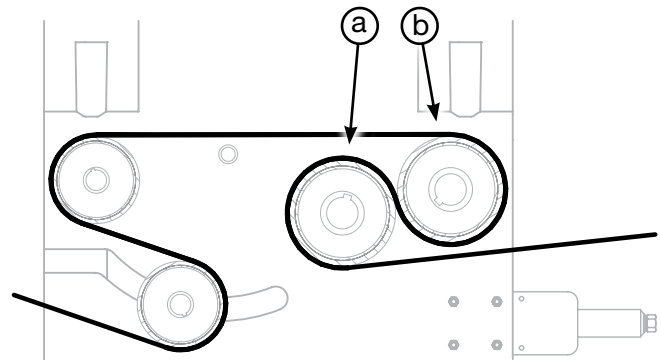

Fig 69 - Drive box, pinch roller (a) & drive roller (b)

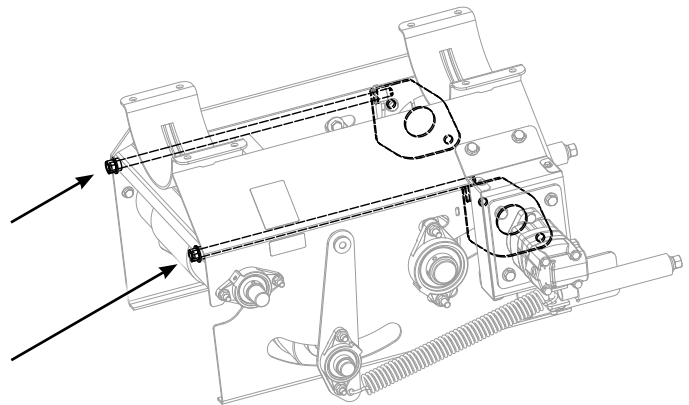

Fig 70 - Adjustment bolts and brackets inside drive box



Fig 71 - Inside discharge spout

4.3.3 Conveyor Belt Replacement:

1. Rotate the conveyor belt until the Alligator® lacing is positioned under the tube, inside the wind guard, and is accessible.
2. Rotate the tension bolts, at the drive box, to their loosest position.
3. Pull all the slack to the lacing area.
4. Remove the lacing cable and open the belt.
5. Attach the new belt to the end of the old belt which is hanging closest to the hopper.
6. Pull the end of the old belt which is coming from the direction of the discharge spout.
 - The new belt will follow and be threaded into place.
7. Link the ends of the new belt lacing.
8. Push the lacing cable through the lacing to fasten belt together.

Note:

Cordless drill can be used to thread cable.
Proceed slowly.

9. Cut off excess cable.
10. Crimp lacing at one end to lock cable in place.
11. Cut and taper belt corners of the trailing end of the belt.

IMPORTANT:

Taper the belt corners, so they don't catch when running.

12. Set belt tension. Refer to Sections 4.3.1
13. Set the belt alignment. Refer to Section 4.3.2

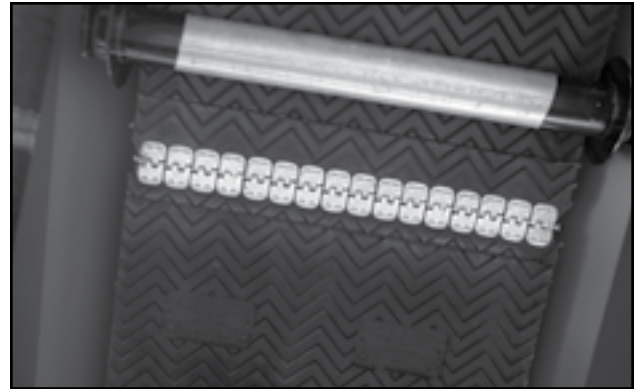

Fig 72 - Conveyor belt lacing

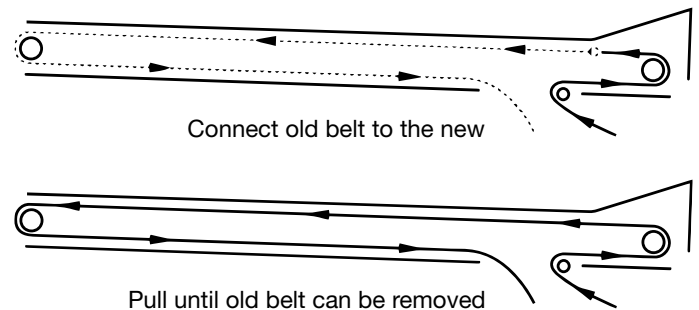

Fig 73 - Thread belt through conveyor

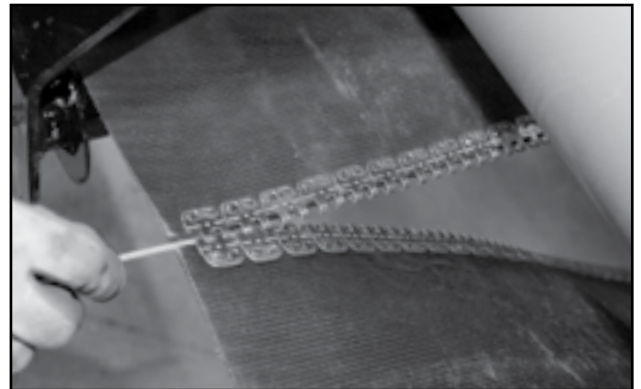

Fig 74 - Thread lacing cable

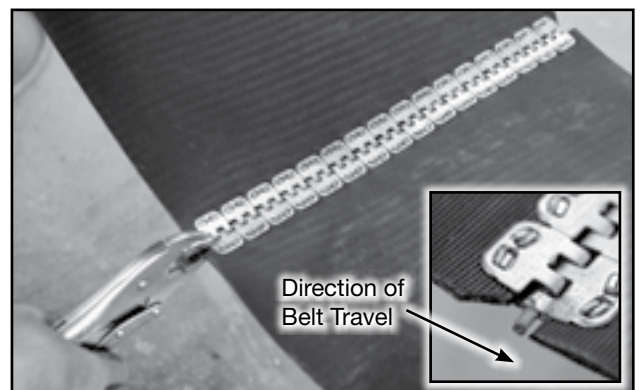

Fig 75 - Crimp lacing and taper belt corners

4.3.4 Drive Belt Tension:

Always adjust the belt tension on the drive-side first.

⚠ WARNING

ROTATING PART HAZARD
Turn off engine. Lock out power and wait for belts to stop moving.



Fig 76 - Countershaft-to-Drive belt with guard open

Countershaft-to-Drive Belt Tension:

1. Open the guard over the V-belt pulley.
2. Loosen counter shaft bearing mount anchor nuts and lock nuts.
3. Use bearing mount position bolts to set countershaft position and set belt tension. Calculate the tension, see Figure 79:
 - Measure the span between pulleys.
 - Allow 1/64" of deflection per inch of span.
4. Tighten bearing mount anchor nuts.
5. Tighten adjusting bolt(s) and lock nut(s).
6. Close and secure guard over pulleys.

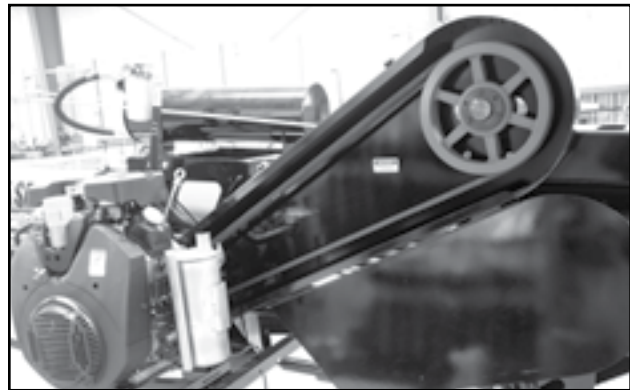

Fig 77 - Engine-to-Countershaft with guard open

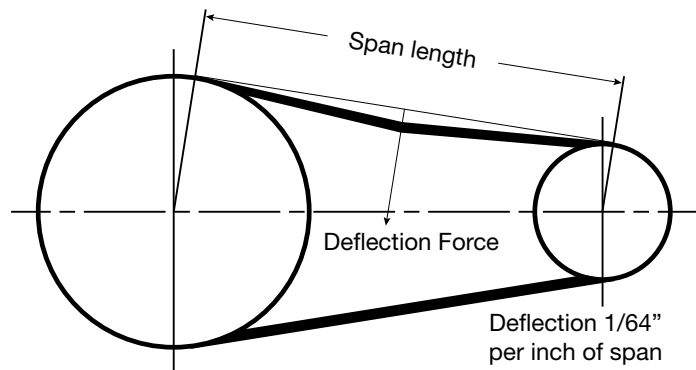

Fig 78 - Tension calculation

Engine-to-Countershaft Belt Tension:

7. Open the guard over the V-belt pulley.
8. Loosen engine mount nuts and jam nuts.
9. Use engine mount nuts to set belt tension. Calculate the tension, see Figure 79:
 - Measure the span between pulleys.
 - Allow 1/64" of deflection per inch of span.
10. Tighten engine mount anchor nuts.
11. Tighten adjusting bolt(s) and lock nut(s).
12. Close and secure guard over pulleys.

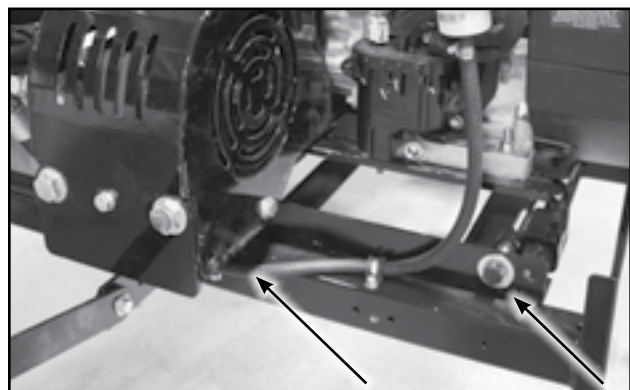

Fig 79 - Engine mount bolts

4.3.5 Check Pulley Alignment:

1. Lay a straight edge across both drive and driven pulleys to check alignment.
2. Use the tapered lock hub in the centre of the pulley to adjust the position of a pulley if required.
3. Move a pulley to align if there is more than a 1/32 inch gap between the edge of the pulley and the straight edge.



Fig 80 - Belt drive with guard opened

4.3.6 Drive Belt Replacement:

1. Place drive system into its loosest position.
2. Remove old belt.
3. Install replacement belt.
4. Set belt tension. Refer to Section 4.3.4
5. Check pulley alignment. Refer to Section 4.3.5

Table 1 - Belt Deflection Force

CROSS SECTION	Smallest Sheave Diameter Range	RPM Range	BELT DEFLECTION (FORCE POUNDS)			
			Uncogged Hy-T® Belts And Uncogged Hy-T® Torque Team®		Cogged Torque Flex® And Machined Edge Torque Team® Belts	
			USED BELT	NEW BELT	USED BELT	NEW BELT
A, AX	3.0 - 3.6	1000-2500 2501-4000	3.7 2.8	5.5 4.2	4.1 3.4	6.1 5.0
	3.8 - 4.8	1000-2500 2501-4000	4.5 3.8	6.8 5.7	5.0 4.3	7.4 6.4
	5.0 - 7.0	1000-2500 2501-4000	5.4 4.7	8.0 7.0	5.7 5.1	9.4 7.6
B, BX	3.4 - 4.2	860-2500 2501-4000	n/a	n/a	4.9 4.2	7.2 6.2
	4.4 - 5.6	860-2500 2501-4000	5.3 4.5	7.9 6.7	7.1 6.2	10.5 9.1
	5.8 - 8.6	860-2500 2501-4000	6.3 6.0	9.4 8.9	8.5 7.3	12.6 10.9
C, CX	7.0 - 9.0	500-1740 1741-3000	11.5 9.4	17.0 13.8	14.7 11.9	21.8 17.5
	9.5 - 16.0	500-1740 1741-3000	14.1 12.5	21.0 18.5	15.9 14.6	23.5 21.6
D	12.0 - 16.0	200-850 851-1500	24.9 21.2	37.0 31.3	n/a	n/a
	18.0 - 20.0	200-850 851-1500	30.4 25.6	45.2 38.0	n/a	n/a
			Uncogged Hy-T® Wedge Belts and Uncogged Hy-T® Wedge Torque Team®		Cogged Hy-T® Wedge Belts and Hy-T® Wedge Machine Edge Torque Team®	
			USED BELT	NEW BELT	USED BELT	NEW BELT
5V	4.4 - 6.7	500-1749 1750-3000 3001-4000	n/a	n/a	10.2 8.8 5.6	15.2 13.2 8.5
	7.1 - 10.9	500-1740 1741-3000	12.7 11.2	18.9 16.7	14.8 13.7	22.1 20.1
	11.8 - 16.0	500-1740 1741-3000	15.5 14.6	23.4 21.8	17.1 16.8	25.5 25.0

4.3.7 Change Hydraulic Oil:

Use an ISO grade 36 hydraulic oil for all operating conditions (Hydrex MV36 or comparable).

Oil reservoir capacity is: 25 Litres (6.25 US Gal).

⚠ WARNING

HOT COMPONENTS HAZARD

Allow engine to cool before changing oil.
Hot oil will burn if it contacts exposed skin.

1. Place all controls in neutral, stop engine and remove ignition key before maintaining.

IMPORTANT:

Annually, have an oil sample tested for particle count.

Change oil only if necessary.

2. Allow the hydraulics to cool slightly before changing oil.

Note:

It is best to change oil while the engine is warm (not hot) to keep contaminants in suspension.

3. Place a large pan, pail or tank under the drain plug.
4. Remove the drain and allow the oil to drain for 10 minutes.
5. Install and tighten the drain plug.
6. Dispose of the used oil in an approved container and manner.
7. Fill the reservoir with specified oil.

4.3.8 Change Hydraulic Oil Filter:

1. Place a pan under the filter to catch any spilled oil.
2. Remove hydraulic oil filter and dispose of it.
3. Fill the new filter with specified oil.
4. Apply a light coat of oil to the O-ring and install the replacement filter. Snug up by hand and then tighten another 1/2 turn.
5. Run the engine for 1-2 minutes and check for oil leaks.
6. If leaks are found around the drain plug or filter, tighten slightly.
7. Check oil level. Top up as required.

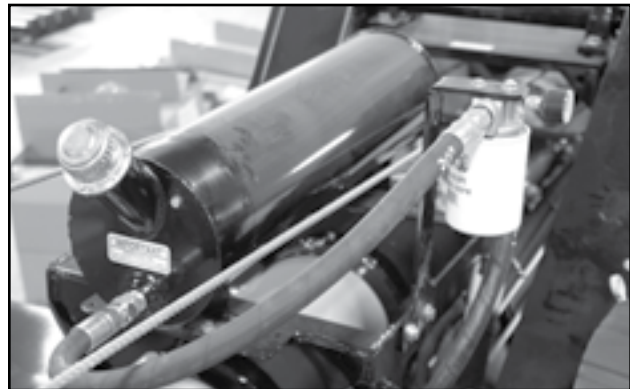
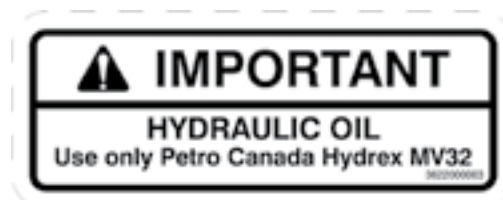

Fig 81 - Hydraulic Oil Reservoir and Filter



3622000003

Fig 82 - Hydraulic Oil decal

4.3.9 Hopper Flashing Replacement:

This is an image of our standard conveyor hopper before the belt is threaded.



Fig 83 - Standard hopper

1. Install the Hopper Tail Flashing onto the front of the hopper, first.

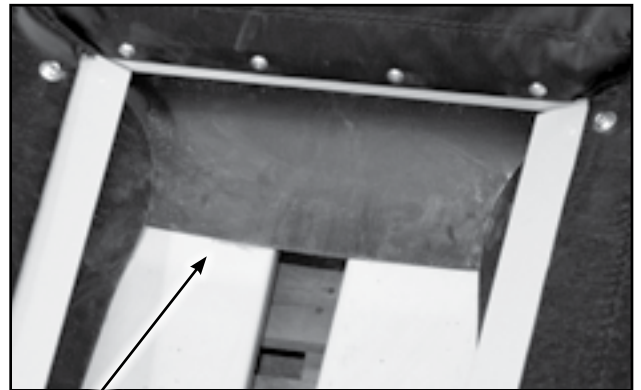

Fig 84 - New tail flashing

2. The Hopper Side Flashing must be placed over top the Tail Flashing.

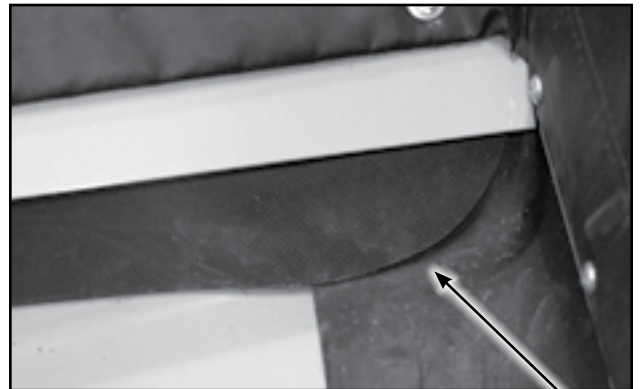

Fig 85 - New side flashing

3. When the conveyor belt is threaded through the tube and hopper, be sure to pull it underneath the Side and Tail Flashing.

IMPORTANT:

The hopper flashing must sit on top of the conveyor belt, to work correctly sealing the hopper.

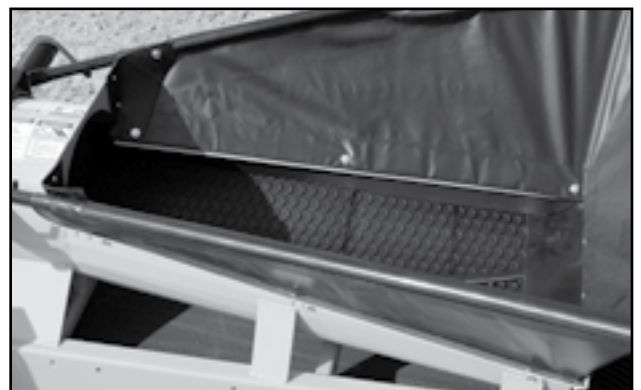

Fig 86 - Completed hopper with belt

4.3.10 Drive Wheel Gear Adjustment:

There must be good engagement between the drive motor pinion gear and the wheel ring gear. Both should be parallel with each other and 90° to the conveyor axle.

- The pinion gear is 3/8" wider than the wheel gear.
- When installing, the pinion gear surface should be offset from the wheel gear by 3/16" on each side.

To adjust the gears:

1. Bring the pinion gear close to the ring gear but not touching.
2. Rotate the conveyor wheel so you can find the "low spot".
3. Engage the motor pinion gear but not so that it will bottom out.
IMPORTANT: The gears should not fit too tightly against each other.

If more engagement is required, the outer 1/2" flange nut can be loosened at the bottom of the handle. The 1" slot in the bottom of the handle will allow it to be lifted up which will mesh the drive gear deeper into the wheel gear.

Retighten the hardware by holding the pivot bolt secure with a wrench.

- Tighten the inner 1/2" flange nut against the three stacked washers and then back off 1/2" turn to allow free play of pivot bolt in the over-centre bracket.
- Tighten the outer 1/2" flange nut against the handle.

Check to ensure the pivot bolt moves freely in the over-centre bracket.



Fig 87 - Bin fill conveyor drive wheel



Fig 88 - Bin fill conveyor drive gears

4.3.11 Hydraulic Drive Motor Replacement:

1. Remove the wheel from the axle.
 - Disconnect the hydraulic hoses to the motor.
 - Take off the pinion gear.
 - Remove the used motor.
2. Bolt on the new hydraulic motor using the existing motor mount.
3. Push the pinion gear onto the shaft.
 - Align the hole in the gear with the shaft.
 - Insert the roll pin to fasten them together.

Note:

If needed, remove assembly components, apply anti-seize lubricant between the parts.

4. Be sure all bolts on the drive assembly are tight.
5. Bolt the wheel back onto the axle.
6. Work the handle up and down.
 - Make sure that there is good contact between motor pinion gear and wheel gear.
 - Both should be parallel with each other and 90° to the conveyor axle.
 - The pinion gear is 3/8" wider than the wheel gear. When installing, the drive gear surface should offset from the wheel gear by 3/16" on each side.
7. The only adjustment possible is to fine-tune the position of the 4" bolt.
 - Loose if the handle movement is too tight.
 - Tighten if the handle has too much play.

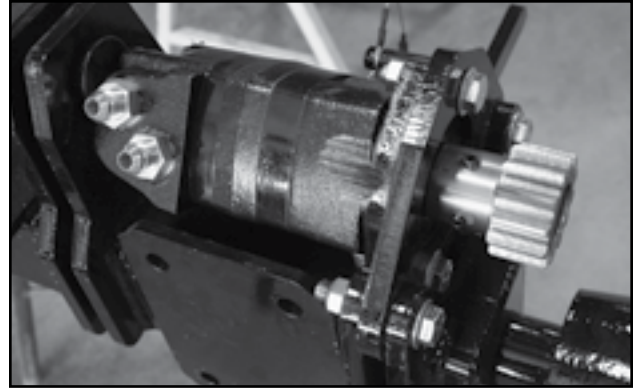

Fig 89 - Pinion gear

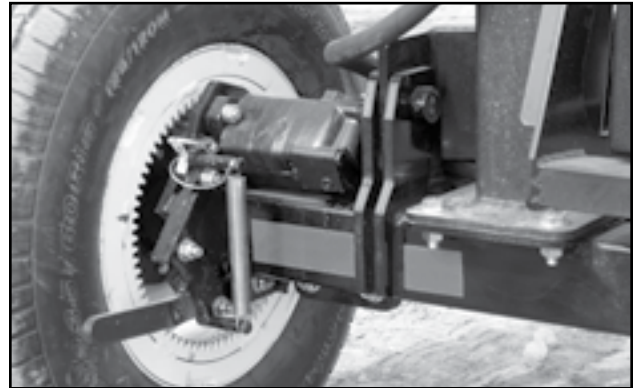

Fig 90 - Wheel ring gear and drive motor

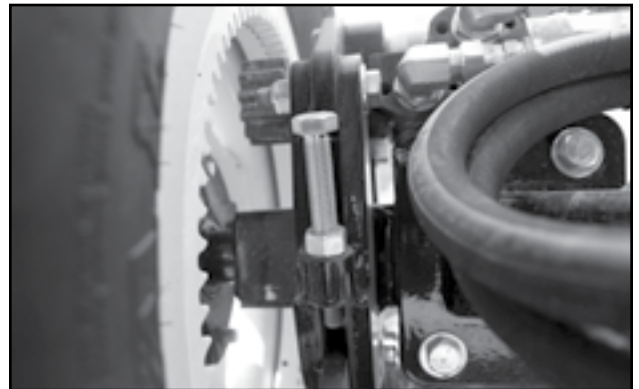

Fig 91 - Adjustment bolt

This page intentionally left blank

4.4 SERVICE RECORD

See Section 4.2 for service intervals. The section is only a general guide under good conditions. Under extreme, or unusual circumstances adjust service timing accordingly.

For more detailed schedule pertaining to specific engine model, consult its Operator Manual.

Copy this page to continue record.

Maintenance	Hours																		
	Serviced By																		
10 Hours or Daily																			
Check Fuel Level																			
Check Hydraulic Oil Level																			
Inspect Conveyor Belt Lacing																			
Inspect Rollers and Bearings																			
50 Hours, or Weekly																			
Check Conveyor Belt Tension																			
Check Conveyor Belt Alignment																			
Check Drive Belt Tension																			
Check Pulley Alignment																			
Check Hopper Flashing																			
Inspect Drive Wheel Sprockets																			
100 Hours or Monthly																			
Grease Hopper Roller Bearings																			
Grease Counter Shaft Bearings																			
Grease Drive Box Bearings																			
Grease Discharge Roller Bearings																			
200 Hours or Annually																			
Change Hydraulic System Oil and Filter																			
Check Battery Charge																			
Grease Steering Wheel Axel Bushings																			
Grease Steering Wheel Lift Cylinders																			
Grease Conveyor Tube Lift Cylinders																			
Check Tube Straightness																			
Repack Wheel Bearings																			
Wash Entire Conveyor																			

4.5 ORDERING PARTS

Always give the Model Number and Serial Number when ordering parts.

To get your parts promptly the following information will be required:

- The part name and number
- Your Name, Address, Town, Province/State, Country
- Complete information for shipping

Confirm all phoned in orders in writing. If Purchase Orders are required please note the number on the written order.

Unless claims for shortages or errors are made immediately upon receipt of goods, they will not be considered.

Inspect all goods received immediately upon receipt. When damaged goods are received, insist that a full description of the damage is made with the carrier against the freight bill. If this is insisted upon, full damage can be collected from the transport company.

No responsibility is assumed for delay or damage to merchandise while in transit. Dealers responsibility ceases upon delivery or pickup of shipment from or to the transportation company. Any freight damage claims must be made with the transportation company, not with the dealer.

Section 5: TROUBLESHOOTING

This section contains a list of common problems, causes and offers quick solutions to those issues.

If problems are confronted which are difficult to solve, even after having read through this section, please contact your authorized dealer, distributor or Meridian Manufacturing Inc. Before you call, please have this Operator's Manual and the unit's serial number ready.

Problem

Possible Cause	Possible Solution
-----------------------	--------------------------

Engine Won't Start

Low battery	Recharge or replace
No fuel	Refuel
Cold engine	Open choke
Air filter dirty	Clean or replace the air filter

The Engine Bogs Down

Not enough power	Open the gate to unload more product. This allows the governor to torque and engage.
Hopper flashing too tight	Adjust to loosen the flashing

Conveyor Belt Doesn't Turn Or Is Slipping

Hopper flashing may be stuck to belt, because it is running dry and rubber is heating up	Turn off unit! Manually peel flashing up and off hopper. Then run dry product through to create barrier between flashing and belt
Conveyor belt loose	Tighten and align
Conveyor belt loose because it has stretched	Shorten belt
Conveyor belt frozen to tube from operating in high humidity conditions in extreme cold	Remove conveyor from area of high humidity and continue to run empty so the belt dries prior to freezing
Drive belt loose	Tighten drive belt
No power	Start engine, increase speed to maximum RPM
Drive roller slipping	Tension or replace V-belt
Seized bearing	Check all bearings, Replace any that are rough or seized

continue on next page

Conveyor Belt Doesn't Turn Or Is Slipping, continued

Conveyor belt or roller is jammed	Check for sticks, stones, other objects jammed in belt drive area and remove
Set screw (relief valve) on Dtent on control valve on belt drive valve isn't set correctly	Sweet spot is to turn the set screw all the way in, then turn back 1-1/2 turns. Turning back/out increases volume of flow, turning in increases pressure.

Conveyor Belt Won't Align

Roller lagging may be worn	Replace roller or have it re-lagged
----------------------------	-------------------------------------

Conveyor Belt Fraying

Belt not aligned	Align and adjust tension
------------------	--------------------------

Product Leakage

Product may be getting under the belt at the hopper, travelling up inside the belt and leaking off delivery end	Replace hopper flashing
---	-------------------------

Low Capacity

Conveyor belt not tight enough	Tighten conveyor belt
Conveyor belt not pinched enough	Inside drive box there is a drive roller and pinch roller. Be sure the belt is snug between both rollers
Drive roller is slipping or is worn out	Tighten or replace V-belt
Conveyor angle exceeds 30 degrees	Reposition with a lower tube slope

No Hydraulic Flow

Hydraulic valve closed or plugged	Open hydraulic valve
	Clean or replace hydraulic valve

Drive Wheels Don't Work

Wheels may not be engaged	Remove retainer clip and engage drive mechanism
---------------------------	---

Steering Axle Keeps Sinking To The Ground

Leak in check valve or cylinder	Replace cartridge in check valve, or replace seals in cylinder
---------------------------------	--

Section 6: REFERENCE

For information not included here, or for a digital copy of this manual, please call your dealer, or Meridian Manufacturing Inc. directly for assistance: (800) 665-7259.

Specifications and measurements are subject to change without notice.

Table 2 - Specifications

MODEL	TYPE OF UNDER-CARRIAGE	TUBE DIAMETER	BELT WIDTH	AXLE WIDTH	TRANSPORT HEIGHT	TRANSPORT LENGTH
1665	Scissor Lift	10"	16"	11' 4"	10' 8"	71' 2"
1675	Scissor Lift	10"	16"	11' 4"	12'	80' 11"
1685	Scissor Lift	10"	16"	12' 6"	11' 8"	91' 1"

Transport lengths are measured from end to end.
Transport heights use 19 inch hitch height.

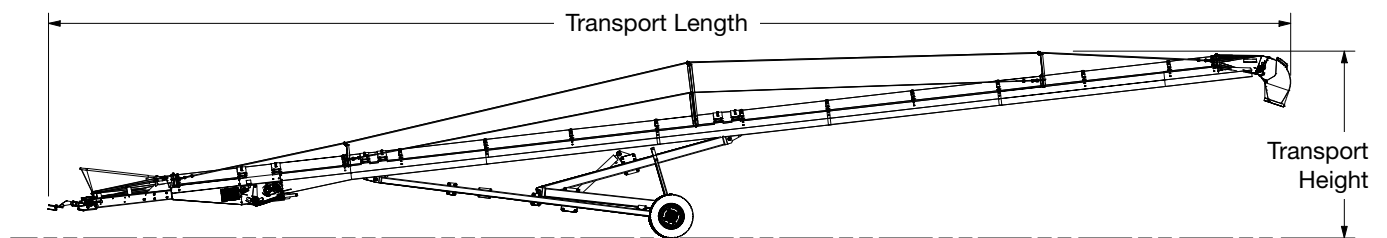

Fig 92 - Transport position

Table 3 - Working Measurements

MODEL	15°			20°			25°			30°		
	HEIGHT	LENGTH	TIRE TO DISCHARGE	HEIGHT	LENGTH	TIRE TO DISCHARGE	HEIGHT	LENGTH	TIRE TO DISCHARGE	HEIGHT	LENGTH	TIRE TO DISCHARGE
1665	16' 2"	64' 7"	32' 4"	21' 10"	63'	31' 4"	27' 5"	60' 11"	30' 1"	32' 8"	58' 5"	28' 7"
1675	18' 7"	74' 6"	42'	25' 2"	72' 10"	40' 9"	31' 7"	70' 7"	39' 2"	37' 9"	67' 10"	37' 3"
1685	21' 2"	84' 2"	45' 4"	28' 7"	82' 3"	43' 11"	35' 10"	79' 8"	42' 2"	42' 9"	76' 6"	40'

Working lengths measured from centre of hopper to centre of discharge.
Tire to Discharge length is measured from rear edge to centre of discharge.

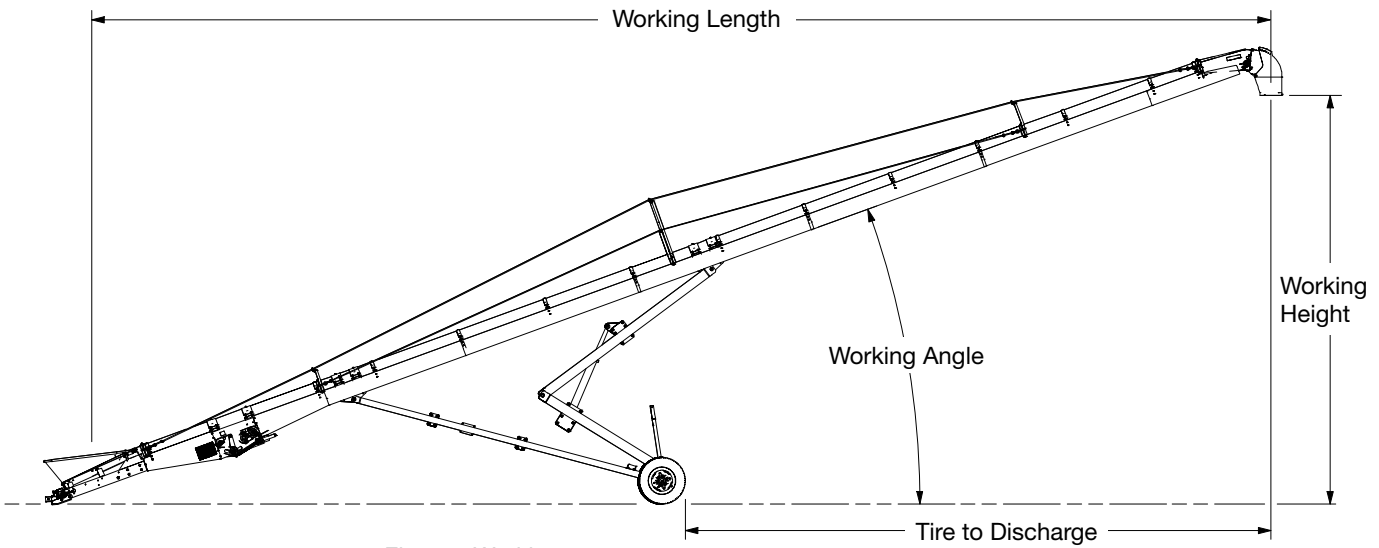

Fig 93 - Working measurements

6.1 BOLT TORQUE

The tables shown below give correct torque values for various bolts and capscrews. Tighten all bolts to the torques specified in chart unless otherwise noted. Check tightness of bolts periodically, using bolt torque chart as a guide. Replace hardware with the same strength bolt.

Table 4 - English Torque Specifications

BOLT DIA. "A"	BOLT TORQUE*					
	SAE 2 (Nm) (ft-lb)		SAE 5 (Nm) (ft-lb)		SAE 8 (Nm) (ft-lb)	
1/4"	8	6	12	9	17	12
5/16"	13	10	25	19	36	27
3/8"	27	20	45	33	63	45
7/16"	41	30	72	53	100	75
1/2"	61	45	110	80	155	115
9/16"	95	60	155	115	220	165
5/8"	128	95	215	160	305	220
3/4"	225	165	390	290	540	400
7/8"	230	170	570	420	880	650
1"	345	225	850	630	1320	970

Table 5 - Metric Torque Specifications

BOLT DIA. "A"	BOLT TORQUE*			
	8.8 (Nm) (ft-lb)		10.9 (Nm) (ft-lb)	
M3	0.5	0.4	1.8	1.3
M4	3	2.2	4.5	3.3
M5	6	4	9	7
M6	10	7	15	11
M8	25	18	35	26
M10	50	37	70	52
M12	90	66	125	92
M14	140	103	200	148
M16	225	166	310	229
M20	435	321	610	450
M24	750	553	1050	774
M30	1495	1103	2100	1550
M36	2600	1917	3675	2710

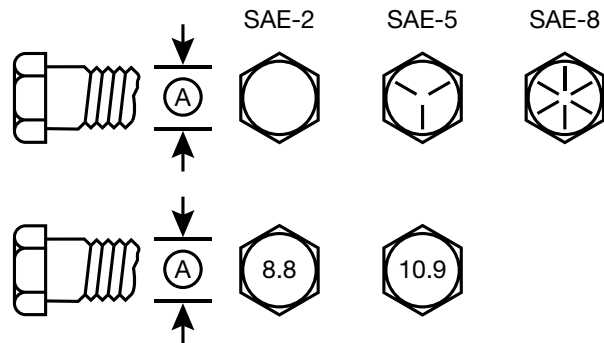

Torque figures indicated above are valid for non-greased or non-oiled threads and heads unless otherwise specified. Therefore, do not grease or oil bolts or capscrews unless otherwise specified in this manual. When using locking elements, increase torque values by 5%.

* Torque value for bolts and capscrews are identified by their head markings.

LIMITED WARRANTY STATEMENT

1. Meridian Manufacturing Inc, hereafter referred to as Meridian®, warrants each new product (the "Goods") to be free from defects in material and workmanship under normal use and service for a period of one (1) year or ninety (90) days in the case of commercial use, from the shipment date from the Meridian dealer (FCA).
2. Meridian warrants replacement parts and components either manufactured or sold by, will be free from defects in materials or workmanship under normal use and service for thirty (30) days from the shipment date from the Meridian dealer (FCA), or the remainder of the original warranty period on the Goods, whichever is longer.
3. This warranty does not apply to:
 - a. To any merchandise or components thereof, which in the sole and unfettered opinion of Meridian, have been subject to misuse, unauthorized modifications, alteration, accident, negligence, product abuse or lack of required maintenance.
 - b. If repairs have been made with parts or by persons other than those parts or persons approved by Meridian.
 - c. To parts and accessories not manufactured by Meridian including, but not limited to, engines, batteries, tires, belts, PTO shafts or other trade accessories. Such parts shall be covered by the warranty given by the actual manufacturer, if any.
 - d. To failure of parts; or failure of parts to perform due to wear under normal or excessive service conditions; or to failure due to use by the Purchaser for purposes other than originally intended at time of manufacture, including without limitation using the Goods for mixing fertilizer, etc.; or used in excess of the built specifications.
 - e. To Goods used in areas exposed to corrosive or aggressive conditions including, but not limited to, salt water from either inside or outside the Goods.
 - f. To failures or defects arising out of damage during shipment or during storage.
 - g. To materials replaced or repaired under this warranty, except to the extent of the remainder of the applicable warranty.
4. The obligation of Meridian under this warranty shall not arise unless Meridian is notified and this warranty is presented together with a written statement specifying the claim or defect within thirty (30) days after the failure is first detected or made known to the Purchaser and within: (i) one (1) year, or ninety (90) days in the case of commercial use; or (ii) thirty (30) days in the case of replacement parts and components manufactured by Meridian; from the shipment date from the Meridian dealer (FCA). Meridian in its sole and unfettered discretion shall determine if the claim is valid and whether correction of the defect or failure shall be made by repair or replacement of the materials.
5. Title to any replaced materials Meridian wishes to have pass to it, shall pass to Meridian.
6. The obligation of Meridian hereunder extends only to the original Purchaser or Buyer to whom the Goods were initially sold. This warranty shall not be subject to any assignment or transfer without the written consent of Meridian.
7. The purchaser acknowledges that it has made its own independent decision to approve the use of the Goods and also the specific fabrication and construction procedures utilized to complete the Goods, and has satisfied itself as to the suitability of these products for its use.
8. This warranty is subject to the following limitations, provisions and conditions:
 - a. Meridian shall have no liability hereunder for any claims, including field re-work.
 - b. Meridian® shall not be liable for any incidental loss or damage, however caused, including, without limitation, normal wear and tear.

- c. Meridian makes no express or implied warranties of any nature whatsoever except for such express warranties as set out herein. The warranty provided herein is in lieu of and excludes all other warranties, guarantees or conditions pertaining to the Goods, written or oral, statutory, express or implied, (except the warranty as to title) including any warranty as to the merchantability or fitness for any particular purpose. Meridian expressly disclaims all other representations, conditions or warranties, expressed or implied, statutory or otherwise and any representations, warranties or conditions that may arise from a course of dealing or usage of trade. The warranty provided herein shall constitute Meridian's sole obligation and liability and the Purchaser's sole remedy for breach of warranty. No other warranty has been made by any employee, agent, or representative of Meridian and any statements contained in any other printed material of Meridian is expressly excluded here from. Meridian shall not be responsible for any warranty offered by the Purchaser to its customers with respect to the Goods and the Purchaser shall indemnify Meridian with respect to same if any of those customers makes a claim against Meridian relating to any such warranty.
 - d. Subject to Meridian's obligations contained in paragraphs 1 and 2 herein, none of Meridian, its officers, directors, servants or agents shall be liable, or responsible for any loss or damage (including strict liability and liability for loss or damage due to items which the manufacturing processes are designed to identify) whether such loss or damage is caused by negligence in any manner whatsoever (including gross negligence, error, misrepresentation, misstatement, imprudence, lack of skill or lack of judgement).
9. The sole financial obligation of Meridian under this warranty shall be limited to the repair or replacement of the Goods as originally supplied and in no event shall they exceed the original cost of the Goods supplied.
 10. Meridian shall not have any obligation under any warranty herein until all accounts have been paid in full by the Purchaser.
 11. The construction and interpretation of this Warranty shall be governed by the laws of the Province of Manitoba.

Register your product at: www.meridianmfg.com
For warranty information send an email to: warranty@meridianmfg.com

WARRANTY CLAIM PROCEDURE

1. The goods must be registered with Meridian Manufacturing Inc.
2. The purchaser must contact the dealer, from where the unit was purchased, immediately upon discovery of any defects.
3. A completed warranty request form must be submitted by the dealer to Meridian's warranty representative for review and any subsequent course of action.
 - Warranty requests must be completed with ALL required information in order for it to be considered for approval.
 - Send photographs of the entire piece of equipment, and of the specific area of concern.
4. Warranty repair work will only be performed by Meridian or an approved representative of Meridian. Warranty work completed prior to approval by Meridian's approval will not be honoured. Failure to follow procedure may affect any or all of this warranty.
5. All warranty requests will be adjudicated at the sole discretion of Meridian and in accordance with the terms and conditions of the limited warranty.

CONVEY-ALL[®]

(800) 665-7259 | www.convey-all.com | conveyors@convey-all.com